



CCW-RV-214W-1S-30-SS-GS-BCB2

Dedicated range of automated, high speed, accurate weighing solutions specifically designed for handling delicate **BISCUITS** and **BAKERY** products.

The RV series from Ishida represents the latest state of the art multihead weighing performance for speed, accuracy and reliability and comes with the industry's leading high performance specification as standard.

This multihead weigher range is designed specifically for weighing fragile, yet free flowing biscuits and bakery products at medium to high speeds e.g. various chocolate coated or non coated biscuits, wafers, ginger bread, mini-pastries, bread rusks.

The Ishida biscuits and bakery weighers have been thoroughly tested to ensure Ishida customers receive the best in class solution for this challenging application.

Dimensions

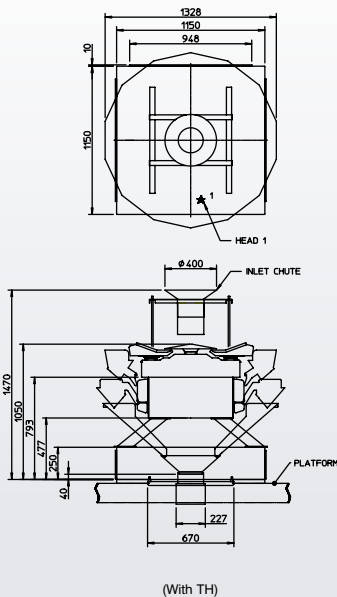

Specifications	CCW-RV-214W-1S-30-SS-GS-BCB2	
Weighing Capacity (per head)	400g	800g
Maximum Volume for Weighing (per dump)	4.5 litres	
Weighing Speed (variable dependent on specific product and target weight)	80 WPM	
Minimum Graduation	0.1g	0.2g
Touch Screen 3D Graphical Display (RCU)	12.1" Colour LCD display including printer (as standard)	
Weigh Cell	Ishida double-beam loadcell	
Vibration control on DFT and RFTs	Pulse width modulation (precise and programmable vibration frequency control - independent from input frequency)	
Number of Presets	200	
Materials	Plain finish 304 stainless steel contact parts	
Machine Weight	Approx. 550kg	
Options	This biscuits and bakery weigher model is a fixed high specification solution dedicated to the specific industry requirements (see specific model details)	
IP test rating of structure	IP54 (see specific cleaning instructions in operators manual)	
Power consumption	0.5kW	
Standard compliance	Ce/UL/FDA/USDA/RoHS	

Design and specifications are subject to change without notice (please confirm dimensions at point of order).



CCW-RV-214W-1S-30-SS-GS-BCB2



RV BISCUITS AND BAKERY 2

Features and benefits



Part of a dedicated range of automated, high speed, accurate weighing solutions specifically designed for handling delicate biscuits and bakery items using Ishida's unrivalled industry experience.

No other multihead weigher supplier can match the experience and global installed base of Ishida and it is this expertise and sector-specific knowledge that has gone into the biscuits and bakery solution.

The biscuits and bakery solution is based on the highest performance RV series multihead weigher platform – this has then been configured for optimum performance for this sector.

Detailed analysis of historic installations, combined with Ishida's expert team of design and application specialists has resulted in the creation of this range of high performance sector solutions.

RV high performance features

- Capable of using all 14 heads in a single combination calculation = 16383 combinations (for maximum efficiency and minimum product giveaway per cycle)
- Simultaneous triple combination calculation (delivering up to 100% efficiency)
- 5 stage digital filter (rapid stable calculations)
- Pulse width modulation on individual radial feeders (precise programmable vibration control to achieve harmonic frequency per radial feeder - independent of input frequency for unrivalled product-specific in-feed control)
- Average weight control software internal calculation resolution to 0.01g (minimise giveaway every cycle)
- Anti-floor vibration with 4 load cells (remove back ground vibration noise from load cell calculation for maximum weighing accuracy and avoiding product giveaway or missed cycles)
- 12.1" remote control unit (RCU) - (large clear screen for rapid programmable control)
- RCU cover as standard (reduce risk of screen damage for long life)
- 200 different product pre-sets (flexible and ensures rapid product changeovers)
- 3D screen display with immediate screen refresh rates (clear intuitive data display to assist operator to continuously monitor and adjust machine performance)
- Ethernet connection - to data link machine performance to customers local area network and internal management systems
- Printer for hard copy read out
- USB access for alternative data capture and transfer
- All materials are FDA approved and comply with Article 16 (1) of Regulation (EC) number 1935/2004, and Article 15 of Regulation 10/2011

Model	BISCUITS AND BAKERY 2 - CCW-RV-214W-1S-30-SS-GS-BCB2	
Max Piece Length	70mm	
Target Volume*	< 1.35 litres	> 3.15 litres
Top Speed*	80 WPM	30 WPM
Contact Parts Finish	Plain finished contact parts (to promote free flow of product and prevent dust build up) with blue metal detectable polyurethane liners where necessary for delicate products	
Dispersion Table	10° dispersion table with skirt and blue urethan coating (for gentle handling of more delicate products)	
Ring Gate	Included with blue metal-detectable polyurethane fingers (controlling product infeed)	
Radial Feeder Troughs	0° radial feeder troughs to increase control of product flow	
Hoppers	Plain finish double opening gentle slope hoppers with blue metal-detectable polyurethane liners (to reduce damage to delicate product)	
Discharge Chutes	Plain finish 42° discharge chute with blue metal-detectable polyurethane liners in the upper section (to receive product delicately)	
Timing Hopper	6 litres motor driven timing hopper included with cover and blue metal-detectable polyurethane liners Options: Double opening, diverting or error diverting	
Software	Multiple languages available, count priority, enhanced average weight control, error signal output, auto zero cleaning mode, remote diagnostics software	

*figures are based on historical application products and may vary depending on specific nature of product



ISHIDA EUROPE LIMITED
Kettles Wood Drive
Woodgate Business Park
Birmingham
B32 3DB
United Kingdom
Tel: +44 (0)121 607 7700
Fax: +44 (0)121 607 7888
info@ishidaeurope.com

ISHIDA CZECH REPUBLIC
Tel: +420 317 844 059
Fax: +420 317 844 052
info@ishidaeurope.cz

ISHIDA ROMANIA
Tel: +40 (0)21 589 73 52
Fax: +40 (0)21 310 34 22
info@ishidaeurope.ro

ISHIDA FRANCE
Tel: +33 (0)1 48 63 83 83
Fax: +33 (0)1 48 63 24 29
info@ishidaeurope.fr

ISHIDA RUSSIA AND CIS
Tel: +7 499 272 05 36
Fax: +7 499 272 05 37
info@ishidaeurope.ru

ISHIDA GERMANY
Tel: +49 (0)791 945 160
Fax: +49 (0)791 945 1699
info@ishida.de

ISHIDA SOUTH AFRICA
Tel: +27 (0)11 976 2010
Fax: +27 (0)11 976 2012
info@ishidaeurope.com

ISHIDA MIDDLE EAST
Tel: +971 (0)4 299 1933
Fax: +971 (0)4 299 1955
ishida@ishida.ae

ISHIDA SWITZERLAND
Tel: +41 (0)41 799 7999
Fax: +41 (0)41 790 3927
info@ishida.ch

ISHIDA NETHERLANDS
Tel: +31 (0)499 39 3675
Fax: +31 (0)499 39 1887
info@ishida.nl