



SLAVUTYCH
TECHNOLOGY

Slavutych Technology Metal detector **Barrier**

User Manual
Revision 4.13 - English
models: -409AE, -409FE



This particular file contains confidential information and is the exclusive property of Slavutych Technology. Any form of reproduction or duplication of this document without explicit written consent from Slavutych Technology is strictly forbidden. Furthermore, this file is an undisclosed creation of Slavutych Technology. In the event of unintentional or deliberate publication, Slavutych Technology is determined to assert its rights over this work according to copyright laws as a published piece. Individuals with access to this file are not permitted to copy, utilize, or disclose the information within unless expressly authorized by Slavutych Technology.



SLAVUTYCH
T E C H N O L O G Y

Barrier

1. Introduction

- 1.1. This operation manual is intended for familiarization of persons operating the «Barrier-409» metal detector (hereinafter - the metal detector), with its design and working principle, functional capabilities, rules of operation, maintenance, storage, and transportation.

The operation manual contains information about the purpose, composition, technical specifications, and electrical parameters of the metal detector. It describes the operating principles of individual parts and the metal detector as a whole, and provides instructions on placement, installation, working order, adjustment, and tuning of the metal detector.

This version of the operation manual fully replaces all previous versions, whose validity is suspended upon receipt of this description.

- 1.2. About this document

Number: BARRIER-409-SL-MN-413-EN

Issue date: 06.10.2025

SLAVUTYCH
T E C H N O L O G Y

Barrier

Index

1.	Introduction	3
2.	Purpose	6
3.	Technical data	7
4.	Construction and operation	9
	4.1. Construction	9
	4.2. Functional diagram of metal detector	10
	4.3. Operation	11
	4.4. Software	12
	4.5. Modbus RTU	13
	4.6. Modbus TCP	15
	4.7. Profinet	16
	4.8. Profibus	18
5.	General guidelines	20
6.	Safety instructions	21
7.	Placement and installation	23
8.	First start	25
9.	Technical maintenance	26
10.	User interface	28
	10.1. Main Window Interface of control module 3B409E	28
	10.2. Detection settings	29
	10.3. Auto ore tuning	30
	10.4. Manual ore settings	32
	10.5. Belt splice settings	33
	10.6. Conveyor influence settings	37
	10.7. Settings of the metal detector	38
	10.8. Diagnostics of the metal detector	38
	10.9. Real-time diagnostic module: Data Analyzer	39
	10.10. User Access Control System.	41
	10.11. Event Log	42
	10.12. Main HMI settings	42
	10.13. States of the metal detector	43

11.	Remote access	45
12.	Factory settings	46
13.	Marking, sealing, and packing	47
14.	Troubleshooting	48

Annexes	49
---------	----

Annex 1. Metal detector modules	50
---------------------------------	----

Annex 2. Connection and wiring schematics	56
---	----

Annex 3. Metal Detector Installation	65
--------------------------------------	----

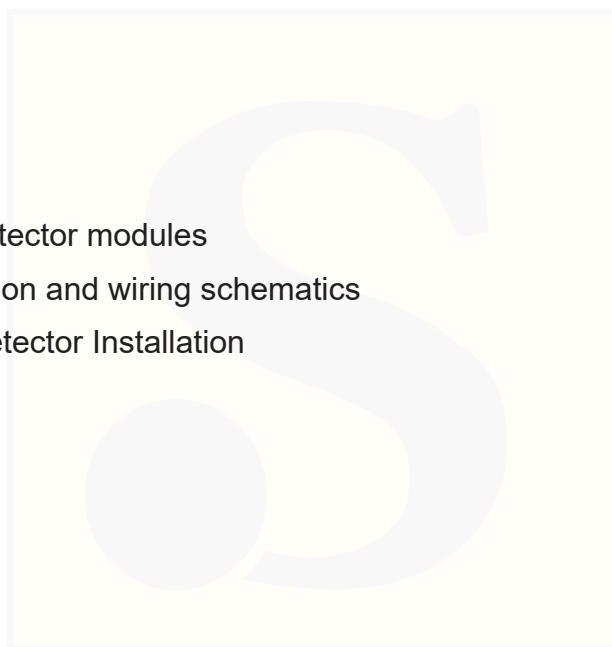

SLAVUTYCH
T E C H N O L O G Y

Barrier

2. Purpose

- 2.1. The metal detector "Barrier-409" is designed for creating metal detection systems, aimed at preventing conveyor belt cuts and protecting crushing equipment (crushers, granulators, cutting equipment) from failures caused by the entry of non-crushable metal fragments into the flow of crushable material.
- 2.2. The protection of crushing equipment and belts is carried out by the metal detector, which detects metal fragments in the flow of solid or bulk materials transported by the conveyor belt, and then by automatically controlling the conveyor movement followed by manual extraction of the metal fragment or by an automatic metal extractor.
- 2.3. The area of application includes ore and concentrate conveyors in the mining industry, crushed stone conveyors in gravel pits, coal conveyors in boiler houses and thermal power plants.
- 2.4. Digital signal processing enables users to optimize the detection process based on product flow rate, physicochemical composition of the monitored material, as well as the type and size of metal fragments, ensuring maximum resistance to external interference.
- 2.5. The metal detector "Barrier-409" is equipped with an RS-485 / Ethernet interface, enabling the connection of metal detectors to the Modbus RTU/TCP network for remote control of metal detector settings and remote diagnostics.

SLAVUTYCH
T E C H N O L O G Y

Barrier

3. Technical data

- 3.1. The metal detector "Barrier-409" may include the modules and components listed in Table 1.

Table 1.

Name	Description
1D204	Conveyor search coil
1C503	Belt clip detector module
1C505	Belt clip detector module
1C301	Metal position module
1C008	Junction box
2M409A	Conversion module
2M409F	Conversion module
3B409E	Control module
3B409E-XXX	Control module
IF4.855.137-10	Cable
IF4.851.136-04	Cable
BARRIER-409-SL-MN-413-EN	User Manual
BARRIER-409-SL-MN-413-UA	User Manual
BARRIER-409-SL-MN-413-PL	User Manual
BARRIER-409-SL-MN-413-ES	User Manual
BARRIER-409-SL-MN-413-FR	User Manual

*

Note.: The first letter A or F after model -409 specifies the conversion module included in the set: 2M409A or 2M409F respectively. The second letter M or E specifies the control module included in the set: or 3B409E respectively. The composition of the "Barrier-409" set is determined by the contract.

- 3.2. Number of control points - one.
- 3.3. Discreteness of detection threshold setting - 4095
- 3.4. Detectable metal - ferromagnetic / non-magnetic / manganese steel
- 3.5. Conveyor belt speed - 0.05 ... 8 m/s
- 3.6. Conveyor belt width - 300 ... 3500 mm
- 3.7. Output signal voltage of the search coil - up to 12V
- 3.8. Time to set the operating mode - up to 30 seconds
- 3.9. Operating mode - continuous
- 3.10. Network protocol - Modbus RTU / TCP / Profibus (Optional) / Profinet (Optional)

- 3.12. The metal detector maintains its technical specifications within the normal range after replacing modules and sensors in it. Replacing one of the modules does not entail adjustment of other modules.
- 3.13. The metal detector is powered by an AC network with a frequency of 47 ~ 63Hz and a voltage from 90 to 260 V. The modules 1C503, 1C301, 2M409 are powered by the remote power supply circuit from 3B409E.
- 3.14. Power consumed by the metal detector from the network: - 15 VA.
- 3.15. The «Barrier-409» metal detector is designed to operate in field conditions with changes in ambient temperature -50 ... +70°C (control module 3B409E -10 ... +70°C); atmospheric pressure - from 84 to 106.7 kPa; relative humidity - up to 95% at 35°C and higher when powered by an AC network with a frequency of 47 ~ 63Hz and a voltage from 90 to 260 V. The unit features an IP66 protection rating, ensuring complete protection against dust ingress and strong water jets from any direction.
- 3.16. The metal detector retains its functionality in the conditions of background gamma radiation with a maximum value of up to 1 µSv/h (100 µR/h).
- 3.17. The metal detector is intended for round-the-clock automatic operation provided that maintenance is carried out.
- 3.18. The unit features an IP66 protection rating, ensuring complete protection against dust ingress and strong water jets from any direction.
- 3.19. Weight and dimensions, not more than:
- 1D204: no more than 4500x1200x700 mm, weight no more than 70.0 kg;
 - 1C503: no more than 400x150x70 mm, weight no more than 2.0 kg;
 - 1C301: no more than 440x125x100 mm, weight no more than 5.0 kg;
 - 2M409A/F: no more than 215x125x90mm, weight no more than 1.5 kg;
 - 3B409E: no more than 400x375x175 mm, weight no more than 8.0 kg.
- 3.20. Dimensional and installation sizes are given in Annex 1.
- 3.21. The average time to failure of the metal detector, taking into account maintenance as regulated by the operating manual, is not less than 80,000 hours.
- 3.22. The average time to restore the working condition of the metal detector is no more than 1 hour.
- 3.23. The total service life is 10 years. The limit state criterion by service life is such a state of the metal detector when the cost of repair exceeds 70% of the cost of the metal detector.

4. Construction and operation

4.1. Construction

4.1.1. The metal detector consists of five main units:

- Conveyor search coil 1D204-XXXX
- Conversion module 2M409A / 2M409F
- Control module 3B409E-XXX
- Belt clip detector module 1C503 / 1C505
- Metal position module 1C301

4.1.2. Conveyor search coil 1D204 is a collapsible frame that wraps around the conveyor belt. It is made of dielectric material with measurement circuits placed on it. The conveyor sensor 1D204 general drawing is presented in Annex 1.1. The conveyor search coil 1D204 is connected to 2M409. (The search coil's design can change depending on the site conditions.) The connection scheme is specified in Annex 2.2 and 2.3.

4.1.3. The conversion module 2M409A / 2M409F is structurally designed as a sealed shock-resistant block, installed on the conveyor sensor frame via special vibration-absorbing supports. 2M409F is connected to 3B409E in accordance with Annex 2.2.

4.1.4. Control module 3B409E can be installed on the conveyor sensor frame or at a distance of not more than 50m from 2M409F. (Standart cable - 10m) The structural design of 3B409E is determined by the operating conditions of the metal detector.

4.1.5. Belt clip detector module 1C503 is an electronic-mechanical device of the tracking type (see Annex 1.2). It is installed on the frame under the belt, before the conveyor sensor at a distance of 1...2 m. The connection scheme is specified in Annex 2.2. 1C503 should be used if the belt joints are connected by metal clamps or rivets.

4.1.6. Metal position module 1C301 is an electronic-mechanical device of the tracking type (see Annex 1.4); it is installed on the conveyor frame. Module 1C301 is necessary for determining the location to search for the detected metal.

4.2. Functional schematic of the metal detector Barrier-409FE

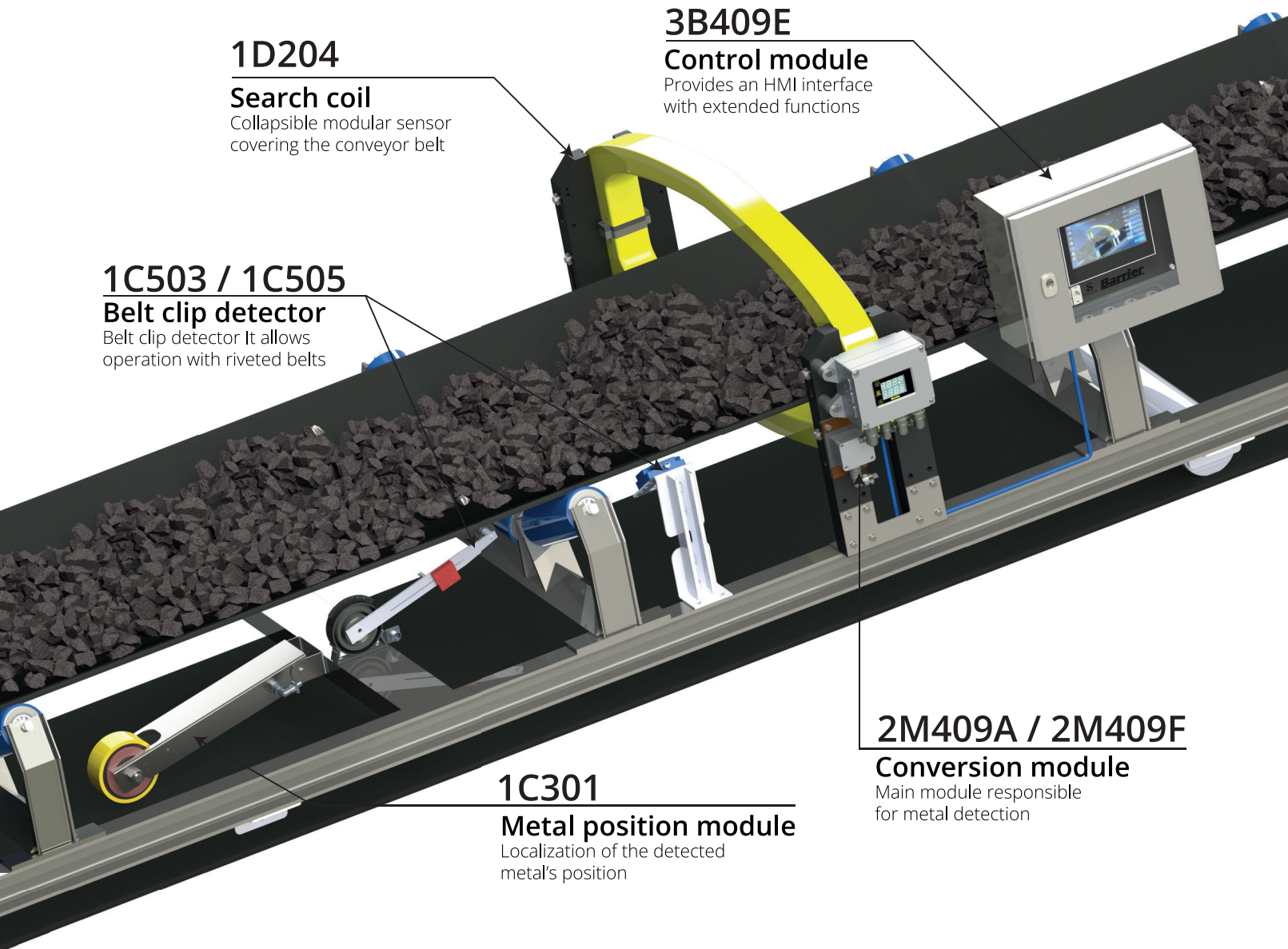

Barrier

4.3. Operation

- 4.3.1. The monitored material, moving with the conveyor belt through the conveyor search coil 1D204, impacts the measuring circuit and causes its mismatch, proportional to the specific conductivity and the surface area of the controlled material.
- 4.3.2. The electrical signal from the conveyor search coil is transmitted to the 2M409A / 2M409F module, which carries out primary filtering and signal conversion from the 1D204, generates a signal corresponding to the metal impurities content on the conveyor belt in the search coil area, converts this signal into digital form, processes signals, calculates calculation parameters, automatic adjustment of the measuring sensor parameters when external working conditions change (changes in temperature, humidity, physical-chemical composition of the transported material, etc.). With an external button panel connected, it is possible to correct the software parameters of the 2M409A / 2M409F module.
- 4.3.3. If there are rivets on the belt, the installation of the 1C503 module is necessary, which determines the level of influence of the joint and controls the algorithm of 2M409A / 2M409F operation so that metal fragments are detected both on the belt joint and near it with the same sensitivity.
- 4.3.4. The 3B409E module receives information coming through the communication channel from 2M409A / 2M409F, controls the conveyor drive and signaling, provides power to the other modules of the metal detector through the remote power circuit.
- 4.3.5. In case of metal detection, the metal detector generates a conveyor stop signal, turns on external sound and light signaling (not included in the supply package), determines the conditional dimension, length of the detected metal and displays it on the 2M409A / 2M409F and / 3B409E modules.









4.4. Software

4.4.1. The main software of the metal detector is located in the memory of the 2M409F module's microcontroller and performs all functions related to metal detection and functions of automatic adjustment to the site conditions.

4.4.2. Changes parameters of the metal detector Barrier-409 is carried out in two ways:

- local adjustment of parameters through the graphical interface of the 3B409E module
- remote by RS-485 / Ethernet

4.4.3. During the operation of the «Barrier-409» metal detector, the following current states are displayed on the indicator of the 2M409 module:

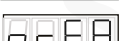
	version of the metal detector
	automatic setting of the metal detector
	control
	belt splice passing
	conveyor stop
	conveyor start
	belt splice passing during the belt splice auto-tuning mode
	threshold auto-tuning
	belt splice auto-tuning
	ore auto-tuning

4.5. Modbus RTU

- 4.5.1. The metal detector "Barrier-409" is equipped with an RS-485 serial interface that supports the Modbus protocol at a high level with an RTU packet format, in full compliance with "Modbus over Serial Line Specification & Implementation guide V1.0."
- 4.5.2. All transmission speeds up to 115200Kbps are supported, but 9600Kbps and 19200Kbps are recommended.
- 4.5.3. Modbus commands comply with the syntax of requests and responses specified in the "Modbus Application Protocol Specification v1.1a." Both broadcast requests (device address 00h) for writing and requests to specific devices according to their addresses are supported.
- 4.5.4. The device address can range from 01h to F7h. The F8h-FFh address range is reserved in the Modbus standard.

4.5.5. Registers:

Table 2.

Coils (command 01h)

Adres	Description
1	RESET - restart of the metal detector
2	Failed to stop the conveyor
3	Restore factory settings

Table 3.

Discrete inputs (command 02h)

Adres	Description
0	Conveyor stop signal
2	Signal from Belt clip detector module
3	Conveyor movement
6	Pressing the external access key left button of the 2M409F module
7	Pressing the external access key right button of the 2M409F module
8	Presence of ore
9	Metal detected

Table 4.
Input register (command 04h)

Adress	Description
0	Signal to stop the conveyor
2	Signal from the Belt clip detector
3	Conveyor motion
8	Variable A
14	Size of detected metal
15	Detection threshold (according to size)
16	Variable AcA
19	Variable Snn
20	Variable rU
21	Variable DCH
28	Distance to the detected metal

Table 5.
Holding registers (command 03h, 06h, 16h)

Adress	Description
0	Detection threshold (according to size)
1	Splice threshold
2	Splice duration
3	Algorithm Splice
4	Threshold at conveyor startup
5	Duration of the threshold at conveyor startup
6	Time to set the operating mode
7	Parameter U
8	Parameter AcPU
9	Modbus Speed: 2400, 4800, 9600, 14400, 19200, 28800, 38400, 57600, 76800, 11520
10	Device address in the Modbus network
11	Ore level for setting "Ore Presence" (symbol is informational, not used in the operation of the metal detector)
12	Time to detect ore presence for setting "Ore Presence"
21	Detection threshold (according to length)

4.6. Modbus TCP

4.6.1. The metal detector Barrier-409, which includes the control module 3B409E, is equipped with an Ethernet interface that supports the Modbus TCP protocol.

4.6.2. IP settings by default

- IP address: 10.10.150.1
- Subnet mask: 255.0.0.0

4.6.3. Registers:

Table 5.

Address	Description
4001	Detection threshold (according to size)
4003	Splice threshold
4005	Splice duration
4007	Algorithm Splice
4009	Threshold at conveyor startup
4011	Duration of the threshold at conveyor startup
4013	Time to set the operating mode
4015	Parameter U
4017	Parameter AcPU
4019	Modbus Speed: 2400, 4800, 9600, 14400, 19200, 28800, 38400, 57600, 76800, 11520
4021	Device address in the Modbus network
4023	Ore level for setting "Ore Presence" (for visualisation only)
4025	Time to detect ore presence for setting "Ore Presence"
4027	Lower range splice 0
4029	Upper range splice 0
4031	Lower range splice 1
4033	Upper range splice 1
4035	Lower range splice 2
4037	Upper range splice 2
4039	Lower range splice 3
4041	Upper range splice 3
4043	Detection threshold (according to length)
4045	Digital filter
4047	Signal to stop the conveyor (metal)
4049	Conveyor motion
4057	Metal size
4061	Variable AcA
4063	Metal flag
4065	Metal length
4067	Distance to the detected metal

4.7. Profinet (optional)

- 4.7.1. The metal detector Barrier-409, can optionally be equipped with Profinet capabilities. In this case, the 3B409E-P control module should be used.
- 4.7.2. Ethernet connector based at the front panel near HMI
- 4.7.3. IP settings by default
- IP address: 192.168.0.111
 - Subnet mask: 255.255.255.0
 - Gateway: 192.168.0.1
- 4.7.4. Profinet capabilities are implemented using the ABC3013 Communicator, which is installed inside the 3B409E-P control module on din rails. To change the Profinet settings, it is possible to connect to its configuration port.
- 4.7.5. Registers:

Table 6.

Adress	End address	Size (bytes)	Description
1	1	1	Conveyor stop ERROR
2	2	1	Metal detected
3	3	1	CONV - conveyor state
4	4	1	Belt clip detector 1
5	5	1	Belt clip detector 2
6	6	1	Ore flag
7	7	1	Metal flag
8	8	1	Splice flag
9	10	2	Iron - Detection threshold (according to size)
11	12	2	Splice threshold
13	14	2	Splice duration
15	16	2	Algorithm Splice
17	18	2	Threshold at conveyor startup
19	20	2	Conveyor start duration
21	22	2	Operation mode establishment time
23	24	2	U - Ore influence parameter
25	26	2	ACD threshold for calculating the U parameter.
27	28	2	Modbus RTU BR
29	30	2	Modbus RTU Adress
31	32	2	Ore lvl (only for HMI)
33	34	2	Ore_tm (Only for HMI)
51	52	2	IronL - Detection threshold by lenght
53	54	2	Digital filter
55	56	2	Number of belt clip detectors
57	58	2	Variable A

Adress	End adress	Size (bytes)	Description
59	60	2	Size of detected metal
61	62	2	Variable Snn
63	64	2	Variable rU
65	66	2	Variable DcH
67	68	2	Detected metal lenght
69	70	2	Distance to the detected metal
71	72	2	Init flag



SLAVUTYCH
TECHNOLOGY

Barrier

4.8. Profibus-DP (optional)

- 4.8.1. The "Barrier-409" metal detector can be integrated into a PROFIBUS-DP industrial network via the ADC3000 communication gateway, which provides protocol conversion in accordance with IEC 61158 and IEC 61784 standards.
- 4.8.2. Communication follows the PROFIBUS DP-V0 protocol for cyclic data exchange. Extended diagnostic and parameterization functions conforming to DP-V1 are available depending on system configuration.
- 4.8.3. The GSD (Generic Station Description) file required for integration with the PROFIBUS master is available upon request via email: office@slavutich-technology.com. It includes definitions of supported communication parameters and data objects.
- 4.8.4. By default, the PROFIBUS interface operates at a baud rate of 19200 bps, and the device is assigned a default station address of 86,87,88 or 89 (modifiable via configuration tools)

Table 7.
PROFIBUS Write Data Mapping

Adress	End address	Size (bytes)	Description
0	1	2	Iron - Detection threshold (according to size)
2	3	2	Splice threshold
4	5	2	Splice duration
6	7	2	Algorithm Splice
8	9	2	Threshold at conveyor startup
10	11	2	Duration of the threshold at conveyor startup
12	13	2	Time to set the operating mode
14	15	2	U - Ore influence parameter
16	17	2	ACD threshold for calculating the U parameter.
18	19	2	Modbus RTU BR
20	21	2	Modbus RTU Adress
22	23	2	Ore level for setting "Ore Presence"
24	25	2	Time to detect "OrePresence"
26	27	2	Detection threshold (according to length)

Table 8.
PROFIBUS Read Data Mapping

Adress	End address	Size (bytes)	Description
0	0	1	Failed to stop the conveyor
1	1	1	Conveyor stop signal
2	2	1	Signal from Belt clip detector module
3	3	1	Conveyor movement
4	4	1	Presence of ore
5	6	2	Signal to stop the conveyor
7	8	2	Signal from the Belt clip detector
9	9	1	Metal detected
10	11	2	Conveyor motion
12	13	2	Variable A
14	15	2	Size of detected metal
16	17	2	Detection threshold (according to size)
18	19	2	Variable AcA
20	21	2	Variable Snn
22	23	2	Variable rU
24	25	2	Variable DCH
26	27	2	Distance to the detected metal
28	29	2	Detection threshold (according to size)
30	31	2	Splice threshold
32	33	2	Splice duration
34	35	2	Algorithm Splice
36	37	2	Threshold at conveyor startup
38	39	2	Duration of the threshold at conveyor startup
40	41	2	Time to set the operating mode
42	43	2	Parameter U
44	45	2	Parameter AcPU
46	47	2	Modbus Speed
48	49	2	Device address in the Modbus network
50	51	2	Ore level for setting "Ore Presence"
52	53	2	Time to detect ore presence for setting "Ore Presence"
54	55	2	Detection threshold (according to length)

5. General Guidelines

- 5.1. The metal detector should be operated by personnel familiar with the general rules for working with electrical equipment and this operation manual.
- 5.2. The metal detector is a complex electronic-physical device that requires qualified handling. Before starting to work with the metal detector, study this document, the design of the device, the purpose of the input and output connectors, as well as the procedure for working with the metal detector. The requirements set out in the technical documentation for the metal detector must be strictly observed.
- 5.3. The metal detector Barrier-409 should be protected from damage. If a malfunction occurs, a full technical service, a technical condition check should be performed, and in case of a negative result, contact the supplying company.
- 5.4. When performing work with the metal detector (maintenance, inspection, etc.), corresponding entries should be made in the form.
- 5.5. When performing work with the metal detector (maintenance, inspection, etc.), corresponding entries should be made in the form.
- 5.6. All methods of connecting the metal detector other than those set out in Annex 2 are prohibited.

SLAVUTYCH
T E C H N O L O G Y

Barrier

6. Safety Instructions

6.1. Important Safety Information

6.1.1. In this manual we use the following safety symbols. These symbols are supposed to draw the readers attention especially to the text next to the safety symbol.



Danger due to High Voltage!

This symbol indicates that there is a potential danger for health and life due to high voltage. Only qualified electricians are allowed to carry out tasks that are marked with this symbol.



All cautionary and warning notices in this manual are identified by this symbol. It is essential to read them carefully and follow all instructions without exception.



Danger due to Moving Parts!

This symbol indicates that exposed moving parts may injure your fingers or hand.

6.1.2. There are two levels of safety messages: warnings and cautions. The distinction between the two is as follows:



WARNING. Failure to follow safe installation and servicing procedures could result in death or serious injury.



CAUTION. Failure to observe may cause minor injury or damage to equipment.

6.2. General Safety Instructions

6.2.1. Below are important safety guidelines to follow during the installation, operation, and maintenance of the Metal Detector BARRIER.



CAUTION

The effectiveness of the system's safety features may be compromised if the equipment is operated in a way that differs from the instructions provided in this manual.



WARNING

Do not attempt to bypass or disable any built-in safety mechanisms. There are no parts inside the system that can be serviced by the user. Only certified Slavutych Technology technicians are authorized to perform maintenance or repairs on this equipment.



WARNING

Users must comply with all relevant safety protocols associated with this equipment. The system enclosure contains components that operate under high voltage and high temperature during normal use.



WARNING:

Electrical leads may carry high voltage that poses a risk of electric shock. Ensure all switches are turned OFF before inspecting AC input connections, inserting or removing circuit boards, or connecting voltmeters to the system.

Exercise extreme caution when performing tests near or within the electronics cabinet, circuit boards, or modules. These areas may contain voltages exceeding 115–230 V.



WARNING:

Ignoring proper installation and servicing guidelines may lead to severe injury or even death.

Installation and maintenance must be carried out exclusively by qualified personnel, following the instructions provided in this manual. Only certified electricians are permitted to access and perform work inside the electronics cabinet, power supply unit, control panel, or electrical enclosures.

7. Placement and Installation

7.1. Conveyor search coil 1D204

should be placed in close proximity to the material under control, ensuring that the distance between the bottom part of the conveyor search coil and the belt (when the belt is loaded) is no less than 50mm for standard applications, no less than 100mm in the presence of a metal belt splice, and no less than 140mm in the case of a steel-cord belt or ore material being transported.

- 7.1.1. The conveyor search coil should be installed at a distance of no less than from 2 to 3 meters from the drive (tension) drum and feed points. The mounting structure of the 1D204 in relation to the conveyor frame should be mechanically rigid and prevent its displacement during operation.
- 7.1.2. There should be no massive moving (with a moving center of gravity) metal objects within 2 meters from the 1D204.
- 7.1.3. The distance from the 1D204 to metallic objects such as steel girders, deck plates, skirt boards, return idlers, or metal building walls should be no less than 1.2 meters.
- 7.1.4. The area of conveyor search coil installation (between two idlers where the search coil is installed) should be cleared of metal sheets, meshes, etc. There should be no transverse metal jumpers in this area.
- 7.1.5. Idler spacing at the coil location must be no less than 1.2 meters if the idlers and rollers are in satisfactory condition, or at least 1.7 meters otherwise
- 7.1.6. Idlers close to the 1D204 coil must be rigidly connected to the conveyor frame, the axis of rotation of the rollers (or idlers) must be isolated on one side, and the bearings of the rollers must be in good condition.
- 7.1.7. In the area where the search coil is installed, the emergency stop cable should run along the conveyor frame.
- 7.1.8. In the case of a riveted or steel-cord belt, the return belt should be shifted down by additional lower limiting rollers so that the distance from the bottom part of the 1D204 to the return belt is not less than 0.5 m.
- 7.1.9. If crosswise displacement of the belt is possible during conveyor operation by more than 0.10 m, side limiting rollers should be installed to avoid mechanical damage to the search head 1D204.
- 7.1.10. Near the search coil installation, there should be no other cables and devices that create electromagnetic fields with an intensity of more than 50 A/m at a frequency of 50 Hz.
- 7.1.11. The troughing carrying idlers closest to the 1D204 should be rigidly connected to the conveyor frame, the rotation axis of the rollers of the specified supports should be rigidly connected to the supports, the bearings of the specified rollers should be in good condition. The parts of the conveyor frame within 3m from the search coil at the joints should be securely fastened by welding.
- 7.1.12. The installation and assembly of the conveyor sensor is depicted in Annex 3.

7.2. Belt clip detector module 1C503

is installed at a distance of up to 1-2 meters from the search coil 1D204, in the direction opposite to the movement of the belt, and is connected to 2M409F / 2M409A with a standard cable IF4.851.139-04. (if Junction Box 1C008 is not used)

- 7.2.1. Belt clip detector 1C503 should be installed so that at the maximum possible transverse displacement of the belt, its tip is in contact with the belt.
- 7.2.2. At the belt junctions, if necessary, install metal clamps parallel to the seam line of the belt from the middle of the belt to its nearest edge, so that the detector's tip passes through the center of the clamp line.

7.3. Belt clip detector module 1C505

is installed at a distance of up to 1-2 meters from the search coil 1D204 and from 50 to 100mm behind first idler before coils, in the direction opposite to the movement of the belt, and is connected to 2M409F / 2M409A with a standard cable IF4.851.139-04. (if Junction Box 1C008 is not used)

- 7.3.1. Belt clip detector 1C505 should be adjusted horizontally and vertically for the 20..30mm maximum distance from the conveyor belt. Detector must be installed and adjusted so that it is parallel to the belt in both direction.
- 7.3.2. In the case of using a belt clip detector on steel-cord belts, it is mandatory to mark the joint of the belt with metal markers; this can be a plate, a staple, or similar ferrous metal.

7.4. Conversion Module 2M409F / 2M409A

is placed at a distance no greater than 1m from the search coil 1D204.

- 7.3.1. It is recommended to mount 2M409F / 2M409A directly on the base of 1D204.
- 7.3.2. Install 2M409F / 2M409A in such a way as to prevent its mechanical damage in the future in case of a technological mass falling from the belt.

7.5. Control Module / 3B409E

is positioned at a distance of up to 50m (max. 100m) from coil 1D204.

- 7.4.1. 2M409F / 2M409A and 3B409E / should be connected by a cable included in the metal detector supply kit. (IF4.855.137-10)

7.6. Electrical Connection Assembly



- 7.6.1. The installation of electrical connections of the metal detector equipment is indicated in Annex 2.
- 7.6.2. Electrical connections from 2M409F / 2M409A to 3B409E are made using the cable (IF4.855.137-10) included in the metal detector supply kit.
- 7.6.3. Connect 1C503 / 1C505 to 2M409F / 2M409A using the cable (IF4.851.139-04) included in the supply kit. (if Junction Box 1C008 is not used)

8. First start

8.1. Checking the Installation.

- 8.1.1. Check the presence of all metal detector modules and ensure that they are securely mounted.
- 8.1.2. Make sure all cables are correctly and securely connected in accordance with Annex 2.
- 8.1.3. Ensure that the assembly work was done correctly for both the loaded and unloaded conveyors:
 - the transported material should not touch the search coil 1D204,
 - in case of steel-cord belt or presense metal clips on the conveyor belt - the return branch of the belt should not come closer than 0.5 m to the bottom part of the search coil 1D204.
 - the tip of 1C503 is in constant contact with the belt (In case of using a metal splice for joining the belt)
 - belt clip detector 1C505 reliably detects metal tags (in the case of a steel-cord belt)
- 8.1.5. Check the rollers closest to coil 1D204: they should be securely connected to the conveyor frame, the rotation axis of the rollers should be solidly connected to the rollers, the bearings of these rollers should be in good condition.

8.2. Powering On

- 8.2.1. The metal detector is activated by supplying ~220V to the appropriate terminals of module 3B409E.
- 8.2.2. After turning on, the metal detector enters automatic balancing mode (flashing symbol on the display  of conversion module 2M409F), and then enters working mode 
- 8.2.3. Ensure that the **CONV** signal is connected and corresponds to the state of the conveyor. (see Annex 2.6, 2.7)
- 8.2.4. Ensure that the **STOP** output is correctly connected to the conveyor blocking circuit upon detection (Annex 2.6).
- 8.2.5. The next setup of the metal detector should be carried out in the following sequence:
 - 1) Ore tuning (10.3)
 - 2) Splice tuning (including in the case of using a steel-cord belt) (10.5)
 - 3) Sensitivity tuning (10.2)

9. Technical Maintenance

9.1. Technical maintenance of the metal detector refers to actions aimed at monitoring its technical condition, maintaining its operability, preventing operational failures, and extending its lifespan. The foundation of technical maintenance is the execution of scheduled inspections of the metal detector during its use and storage.

9.2. Timely and complete performance of tasks related to the technical maintenance of the metal detector during its operation and storage is one of the most crucial conditions to keep it constantly ready for work, maintaining its initial parameters, and ensuring a defined operational period.

9.3. Exterior inspection of the metal detector.

9.3.1. Check for the presence of seals.

9.3.2. Inspect the firmness of the search coil 1D204 mounting, absence of mechanical damages, and cleanliness of the 1D204 surface.



9.3.3. Check the solid mounting of module 2M409 and the cables connected to it.

9.3.4. Inspect the firm mounting of the belt clip detector 1C503 / 1C505, the functionality of its springs, absence of corrosion on parts with galvanic coating, and the condition of its tip.

9.3.5. Clean the external surfaces of the metal detector components with a cloth or brush.

9.3.6. Remove corrosion, non-removable dirt, and oil stains from the surface using a cloth soaked in alcohol.

9.4. Technical Maintenance of 3B409E

9.4.1. Turn on the metal detector by supplying power to the ~220V terminals of the 3B409E module, after which the metal detector auto-calibration mode is initiated (symbol ). After auto-calibration (approximately 1 minute), the 2M409 module switches to monitoring mode (symbol ).

9.4.2. Place a metal object of required dimensions on the moving conveyor. Upon detection of the metal, the 2M409 module of the metal detector switches to the mode of determining the dimensions of the detected metal, and an approximate size of the detected metal appears on the 2M409 module display.



9.4.3. Remove the metal and start conveyor; the 2M409F switches back to the monitoring mode (symbol on the 2M409F display ).

9.5. Technical Maintenance of 2M409

9.5.1. Check the condition of the damping bushings of the 2M409 module by moving the conversion module. If there's a rigid connection between 2M409 and 1D204, loosen the mounting screws, but prevent the 2M409F module from moving freely on the mounting screws. In case of damage to the damping bushings, they should be replaced with new ones.

- 9.5.2. Check the connector connections of the 2M409F module and if necessary, tighten the mounting nuts of the cable part of the connector.
- 9.5.3. Verify the operation of 2M409 in the detection threshold correction mode according to point 10.1. and splice threshold correction mode (clause 10.14).

9.6. Technical Maintenance 1C503 / 1C505

- 9.6.1. Remove corrosion, dirt, and oil stains from the surface using a cloth soaked in an alcohol solution.
- 9.6.2. In case of false alarms or missed metal, check the operation of the belt clip detector when the conveyor belt joint passes through the coil window of 1D204. When the joint of the belt passes over 1C503 (1C505), the symbol  on the 2M409 display should light up, signaling the passage of the joint through 1D204, and the belt should not stop; at other times, 2M409F displays the symbol .
- 9.6.3. To adjust the sensitivity of 1C503, you need to slide the electronic block of the belt detector along the rod, first loosening the screws that secure the electronic block 1C503. Moving the electronic block 1C503 toward the base decreases sensitivity; moving it toward the tip increases it, aiming to trigger 1C503 without false alarms. After adjusting the sensitivity of the joint detector, tighten the screws securing the electronic block 1C503.
- 9.6.4. Check the pressure of the clip detector 1C503 rod on the conveyor belt. During operation on both loaded and unloaded conveyors, the rod 1C503 should track the vertical profile of the conveyor belt. Replace the spring if necessary.
- 9.6.5. When using 2 detector's 1C505, check the sensor's distance from the conveyor belt and ensure that the detection is guaranteed, even if the distance increases by 20%.

9.7. Technical Maintenance 1D204

- 9.7.1. Conduct an external inspection to ensure that there are no mechanical damages.
- 9.7.2. In case of damage to the 1D204 search coil by the belt, replace the damaged frame parts and adjust the belt's path through 1D204 using side guide rollers to avoid further damage to the coil in the future.
- 9.7.3. If the cable is damaged, connect it by soldering and insulate any exposed parts with waterproof insulating tape.
- 9.7.5. Do not pull or sharply bend the cable during inspection and cleaning of contacts in cable connectors; the bending radius should not be less than five cable diameters.
- 9.7.6. Conduct an external inspection of the roller bearings located less than 2 meters from 1D204. In case of increased vibration or noise (squeaking) from the rolling bearings, the rollers must be replaced.
- 9.7.7. Check the idlers close to the 1D204 coil: they must be rigidly connected to the conveyor frame, the axis of rotation of the rollers (or idlers) must be isolated on one side, and the bearings of the rollers must be in good condition.

10. User Interface

10.1. Main Window Interface of control module 3B409E

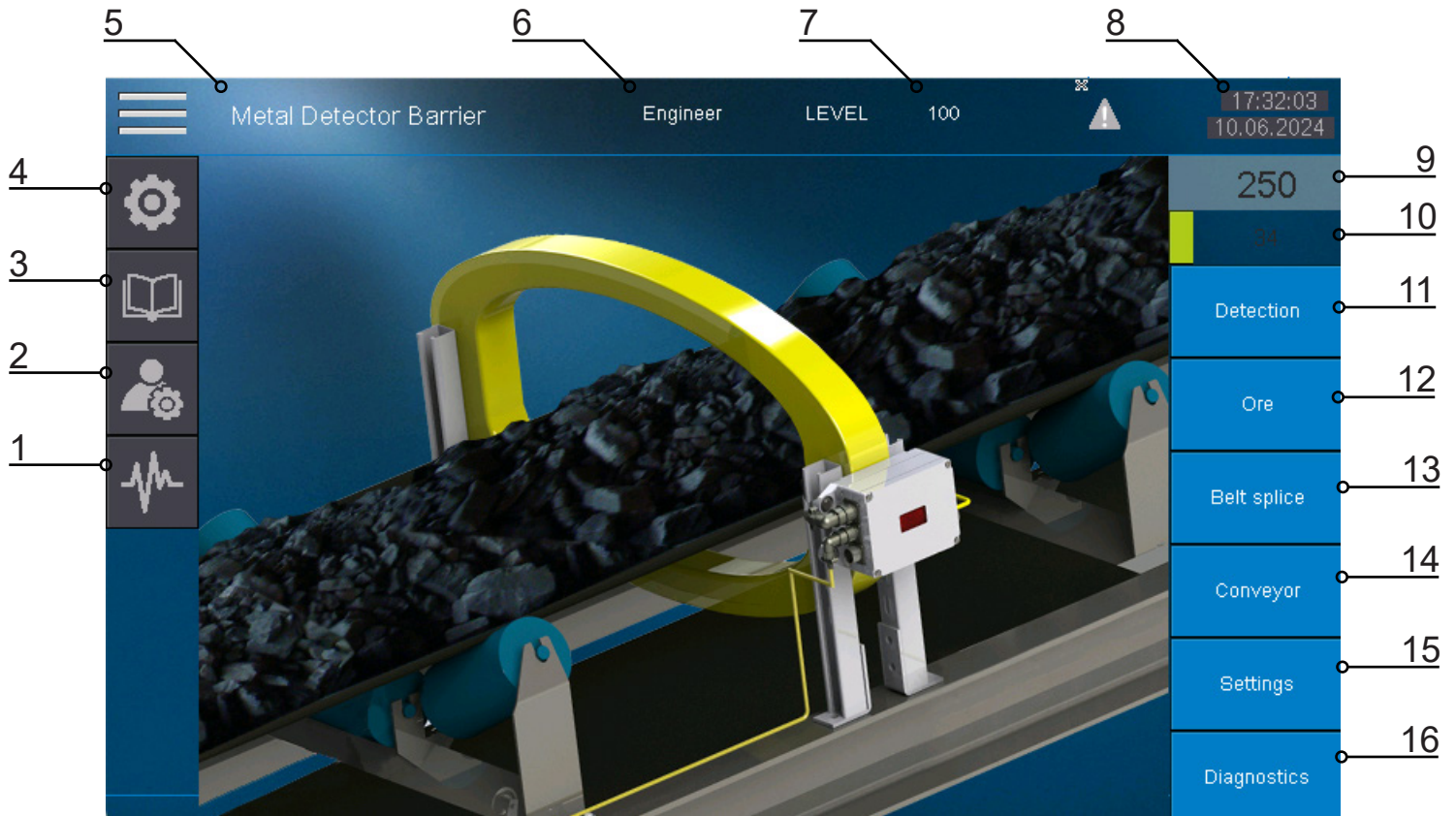

10.1.1 Main interface details of the main window:

- | | |
|---|---------------------|
| 1) Real-time diagnostic module: Data Analyzer | (access level: 20) |
| 2) User profile configuration | (access level: 40) |
| 3) Event log | |
| 4) Main HMI settings | |
| 5) Name: Metal Detector Barrier | |
| 6) Current user | |
| 7) Access level of current user | |
| 8) Date and time | |
| 9) Detection threshold | (access level: 20) |
| 10) Current peak signal | |
| 11) Detection settings | (access level: 20) |
| 12) Ore settings | (access level: 40) |
| 13) Belt splice settings | (access level: 40) |
| 14) Conveyor influence settings | (access level: 40) |
| 15) Main settings of the metal detector | (access level: 100) |
| 16) Diagnostics of the metal detector | |

10.2. Detection settings

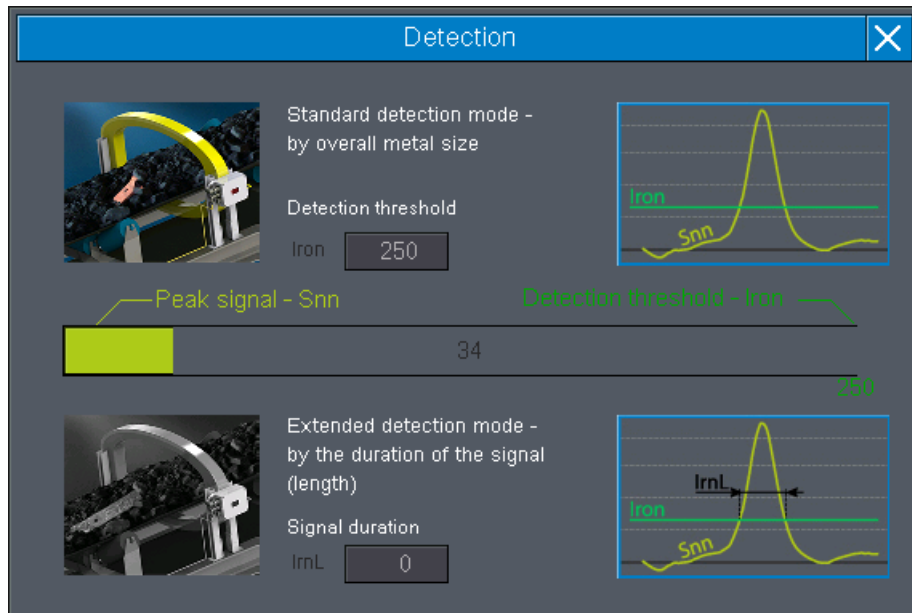

- 10.2.1 The Metal Detector Barrier detects tramp metal when the peak signal (**Snn**) exceeds the detector threshold (**Iron**)
- 10.2.2. The additional detection mode by the duration of the signal (**Snn**), incorporates the length of the pulse, i.e., the length of the tramp metal, into the detection condition. This ensures that the detection of short metal objects is ignored. This mode is typically selected when the metal detector is used to protect conveyor belts from damage by long metals (such as scrap, angle iron, or reinforcing bars). Detection mode by the duration (length) is active when its value is greater than 0.
- 10.2.3. The access levels for Detector threshold (**Iron**) and Detector signal duration (**IrnL**) are 20 and 100, respectively.
- 10.2.4. Open the Data Analyzer, start data plotting, and verify metal detection using metal samples.

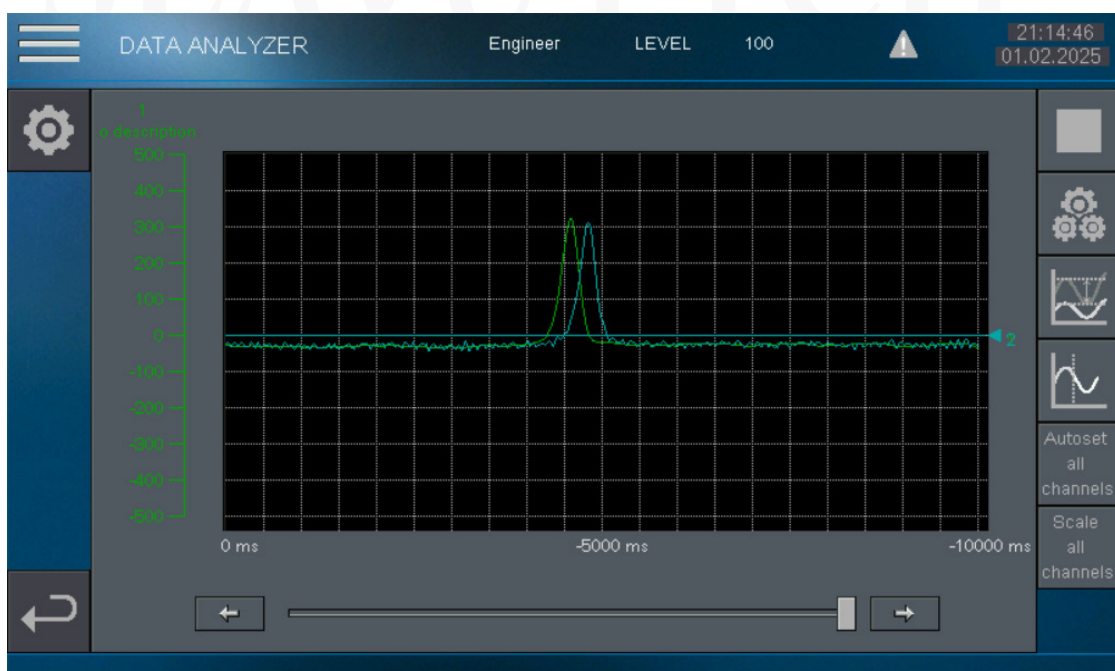

10.3. Auto ore tuning (only for F model)

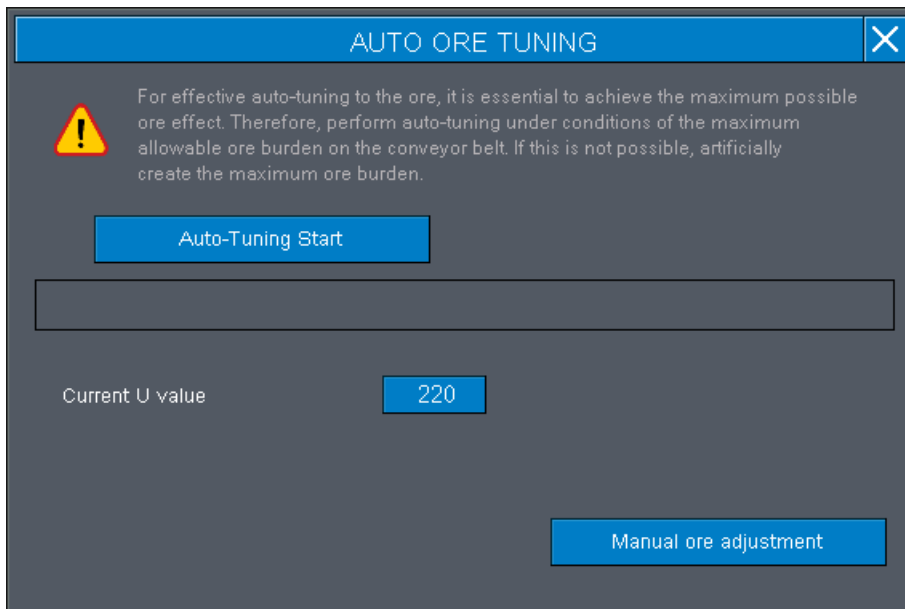

10.3.1 To eliminate the influence of ore, value of the parameter **U** should be adjusted.

10.3.2. To determine the **U** parameter, the auto-tuning process must be initiated by pressing the **Auto-Tuning Start** button.

ATTENTION: Auto-tuning is performed at the maximum possible ore burden on the conveyor belt.

10.3.3. Pressing the **Cancel Auto-Tuning** button during the auto-tuning process immediately terminates the operation. In this case, the tuning results obtained up to that point will be displayed.

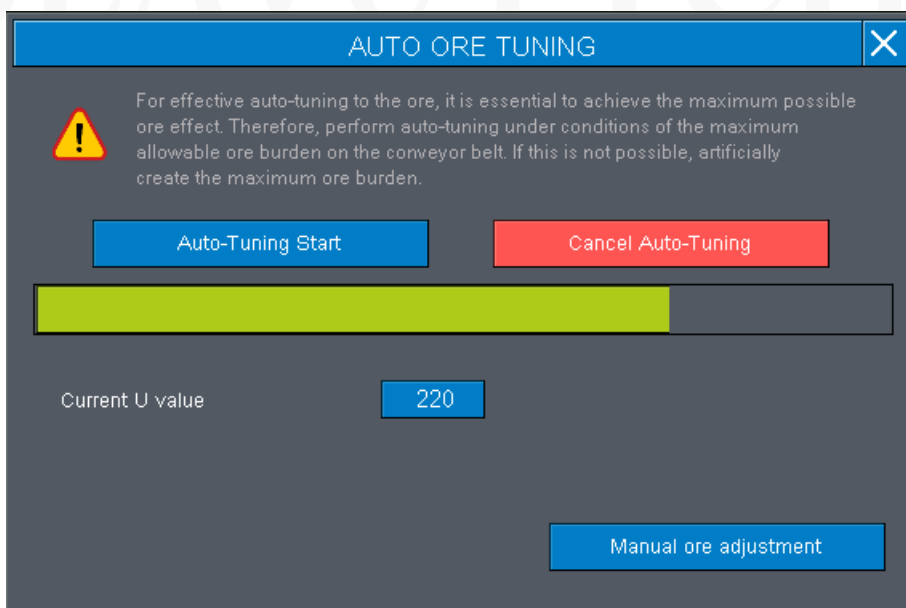

10.3.4. After successful completion of the auto-tuning process, the following results will be displayed:

- The proposed new U parameter value
- The number of measurements taken

If the ore effect is insufficient, no results will be displayed.

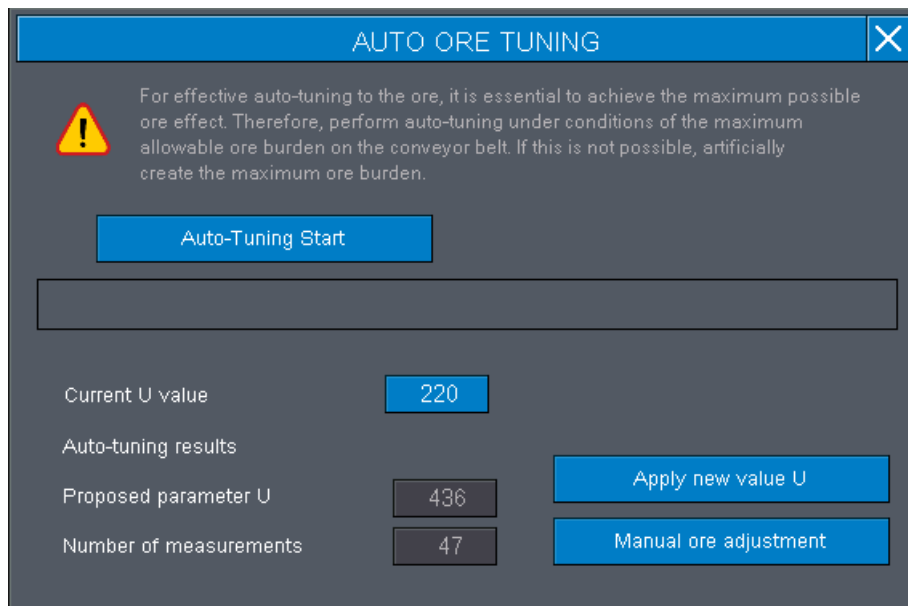

10.3.4. Pressing the Apply New Value U button updates the U parameter based on the auto-tuning results.

10.3.5. To ignore the changes and exit the auto-tuning process, press the X button in the upper-right corner.

10.3.6. To switch to manual ore adjustment, press the corresponding Manual Ore Adjustment button.



SLAVUTYCH
TECHNOLOGY

Barrier

10.5. Belt splice settings

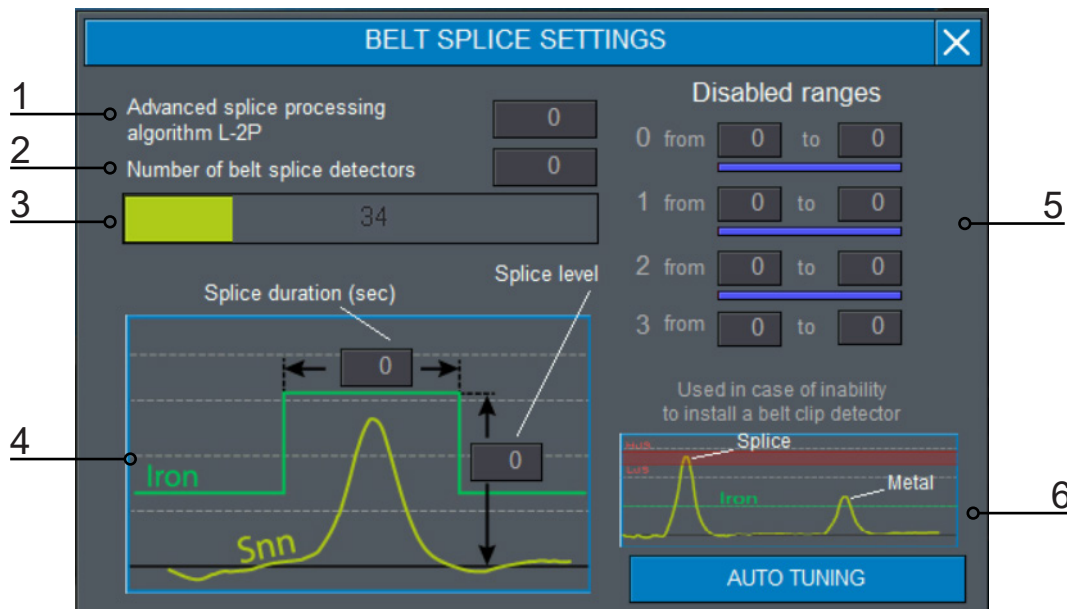

ATTENTION: The splice setting must be performed on a conveyor that is fully loaded with transported material. Additionally, the gap between the belt and the search coil must not be less than 140 mm.

10.5.1 The Barrier-409 metal detector, upon receiving a signal from the belt clip detector 1C503 or 1C505, increases the detection threshold to the **splice threshold** for the duration of the **splice duration**.

In case a second 1C505 is used to determine the splice length, the "Number of belt splice detectors" parameter should be set to 3. The second belt clip detector 1C505 must be installed on the opposite side of the belt, after the metal detector.

10.5.2. Despite this, the Barrier metal detector attempts to detect metal at the splice with sensitivity close to that outside the splice, as much as possible, using the advanced splice processing algorithm **L-2P**. (1). Activation of the **L-2P** algorithm is possible only in the absence of additional metal parts near the splice (patches, additional buckles, and rivets).

10.5.3. The splice level (4) can be determined in two ways:

1) Detect the splice as a regular tramp metal, add 20% to the detected metal size, and record it as the **splice level**.

*For example: If the metal splice is detected as tramp metal, and its size is displayed as 1320 on the main window, then the splice level parameter should be set to $1320 * 1.2 = 1584$.*

2) Increase the **Splice level** for example to 3000. While observing the **Snn** variable (3) during the splice passage, determine its maximum value and record it in the **Splice level**, adding 20% beforehand.

10.5.4. In case it is impossible to identify the splice using the belt clip detector (or if it is absent), it is possible to use disable ranges (5). This algorithm excludes sensitivity zones where metal detection does not occur. Since there is a possibility that tramp metal could also fall within this range and go undetected, it is not recommended to use this function on a permanent basis. However, in cases of urgent belt repairs, patches, or repair clips, this can be a better temporary solution than significantly increasing the overall detection threshold.

10.5.5. There are a total of 4 adjustable disable ranges: 0, 1, 2, 3. Each of them has a lower and upper value (LHD and HDS respectively). (access level: 100)

The operation algorithm for disabled ranges is illustrated below (6):

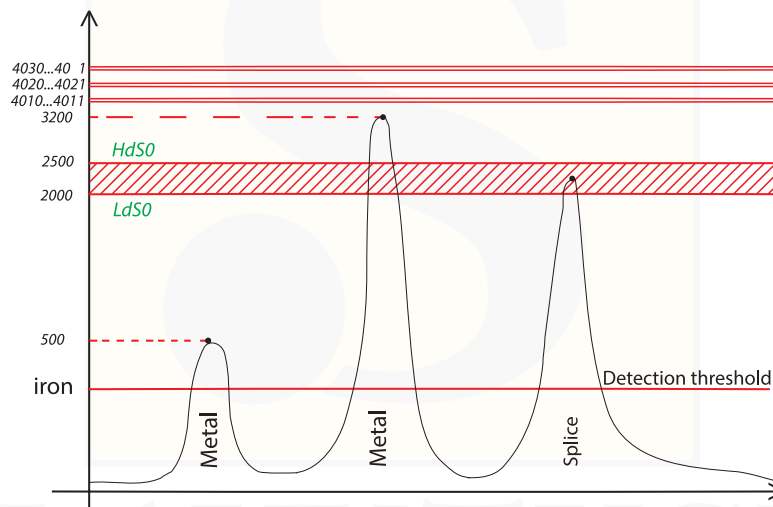

10.5.6. Auto belt splice tuning

10.5.7. Pressing the Auto Belt Splice Tuning key opens the automatic tuning window.

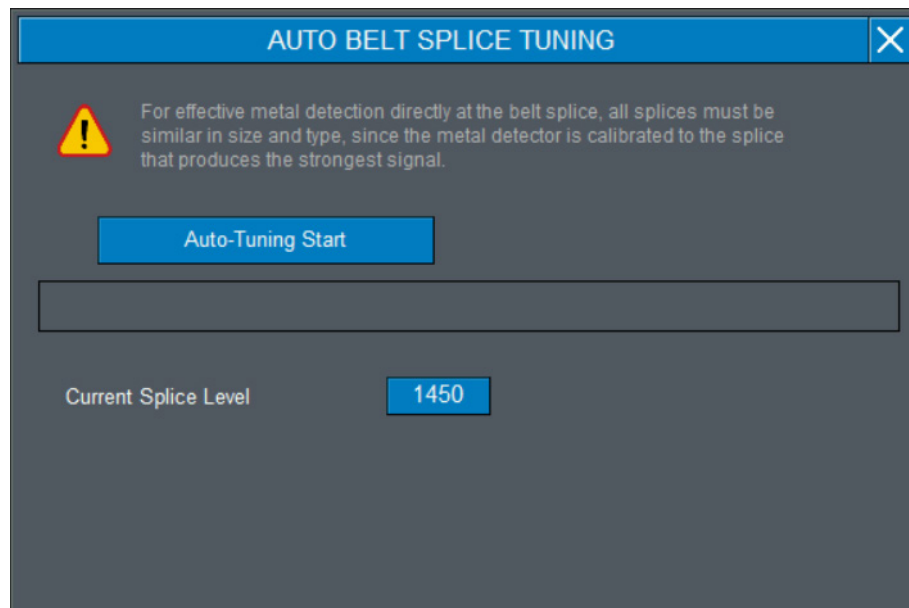

10.5.8 To eliminate the influence of ore, value of the parameter **U** should be adjusted.

10.5.9. To determine the **Splice level** parameter, the auto-tuning process must be initiated by pressing the **Auto-Tuning Start** button.

ATTENTION: For effective metal detection directly at the belt splice, all splices must be similar in size and type, since the metal detector is calibrated to the splice that produces the strongest signal.

10.5.10 Pressing the **Cancel Auto-Tuning** button during the auto-tuning process immediately terminates the operation. In this case, the tuning results obtained up to that point will be displayed.

10.5.11. After successful completion of the auto-tuning process, the following results will be displayed:

- The proposed new Splice parameter value

If no splice is present or the belt clip detector is not connected, no results will be generated.

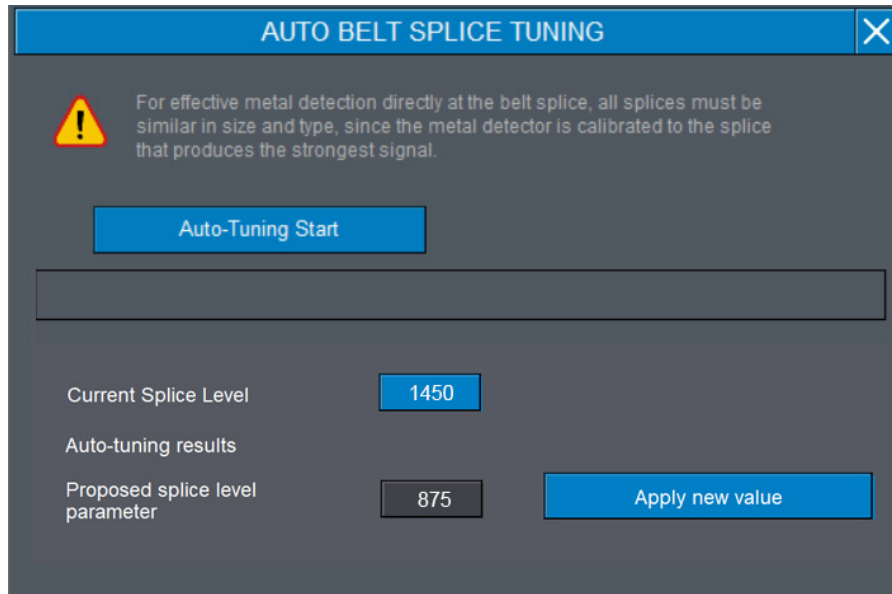

10.5.12. Pressing the Apply New Value button updates the Splice level parameter based on the auto-tuning results.

10.5.13 To ignore the changes and exit the auto-tuning process, press the X button in the upper-right corner.

10.6. Conveyor influence settings

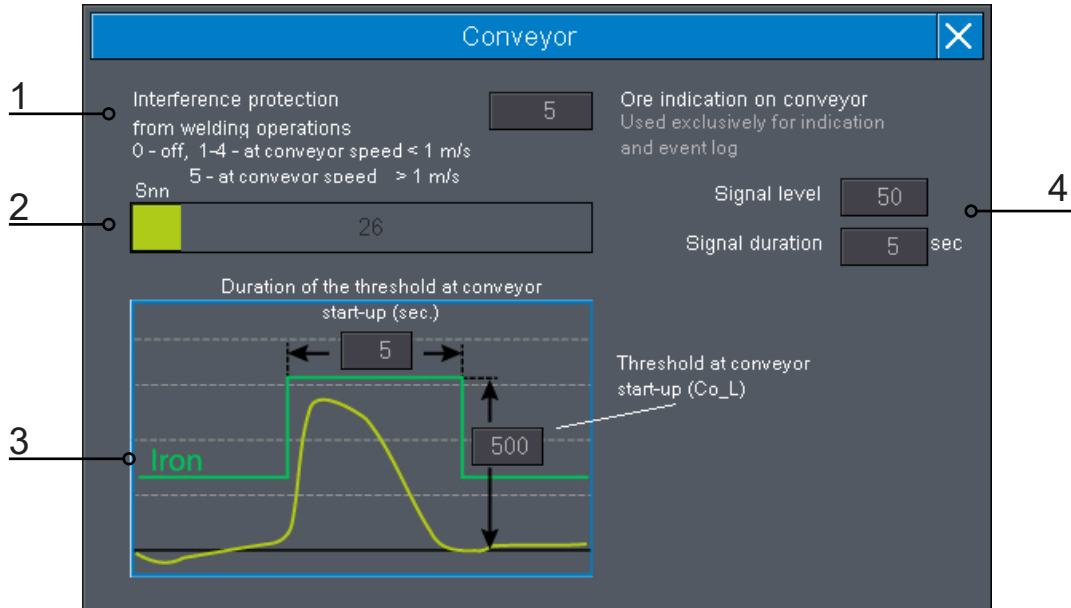

10.6.1 (1) Protection from welding operations or other significant electromagnetic interferences that may occur at the facility is activated by recording the filter algorithm number.

1, 2	- for conveyors with a belt speed less than	0.3	m/s
3, 4	- for conveyors with a belt speed less than	1	m/s
5	- for conveyors with a belt speed greater than	1	m/s

10.6.2. (2) Observing Peak Signal - Snn

10.6.3. (3) In case of false alarms from the metal detector during the starting or stopping of the conveyor belt, the parameters "**Threshold at Conveyor Start-up**" and "**Duration of threshold at Conveyor Start-up**" should be set.

10.6.4. Ore indication on the conveyor is not used in the logic of the metal detector operation, but only for visualization and recordings in the Event Log.

For stable indication, it is necessary to set the "**Signal level**" for ore (determined experimentally) and the duration of ore presence, during which the indication will occur.

10.7. Settings of the metal detector

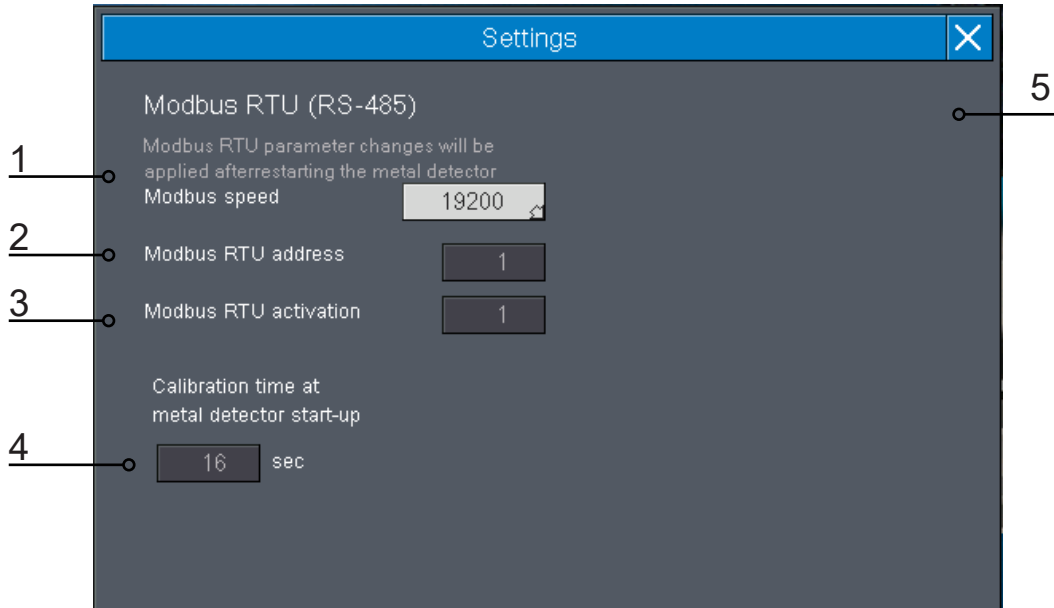

- 10.7.1 (1) Modbus RTU Speed Setting
- (2) Modbus RTU Address
- (3) Activation-Deactivation of Modbus RTU
- (4) Calibration Time when Turning on the Metal Detector
- (5) Metal detection output

10.8. Diagnostics of the metal detector

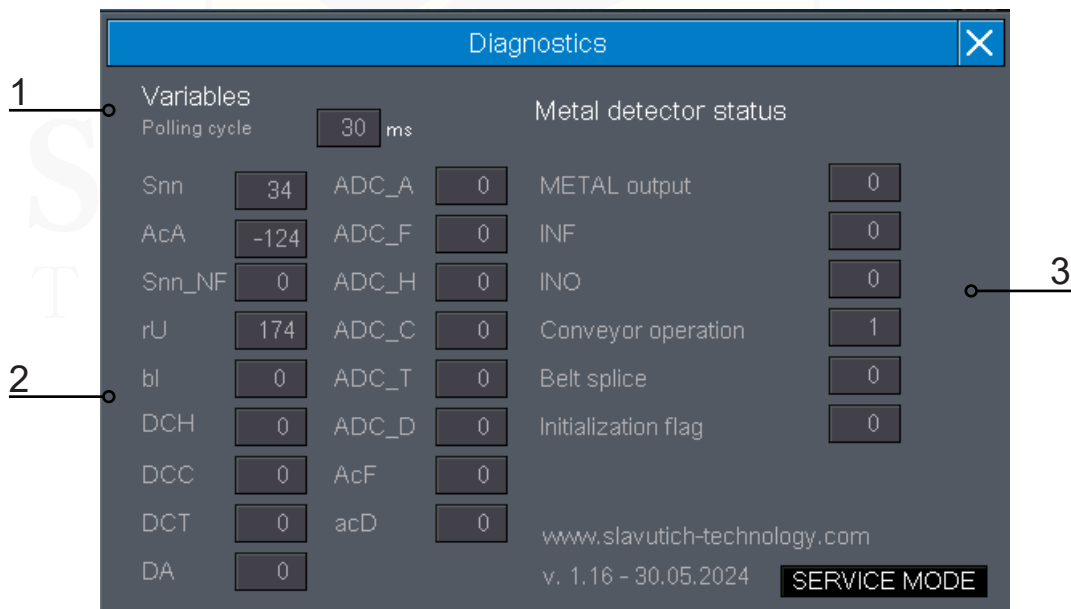

10.8.1 The diagnostics window displays the overall status of the metal detector, which allows for the assessment of its proper installation and configuration on-site.

10.8.2. The Polling cycle value determines the frequency at which the main variables of the Barrier metal detector are updated for display and plotting in the Data Analyzer.

10.9. Real-time diagnostic module: Data Analyzer

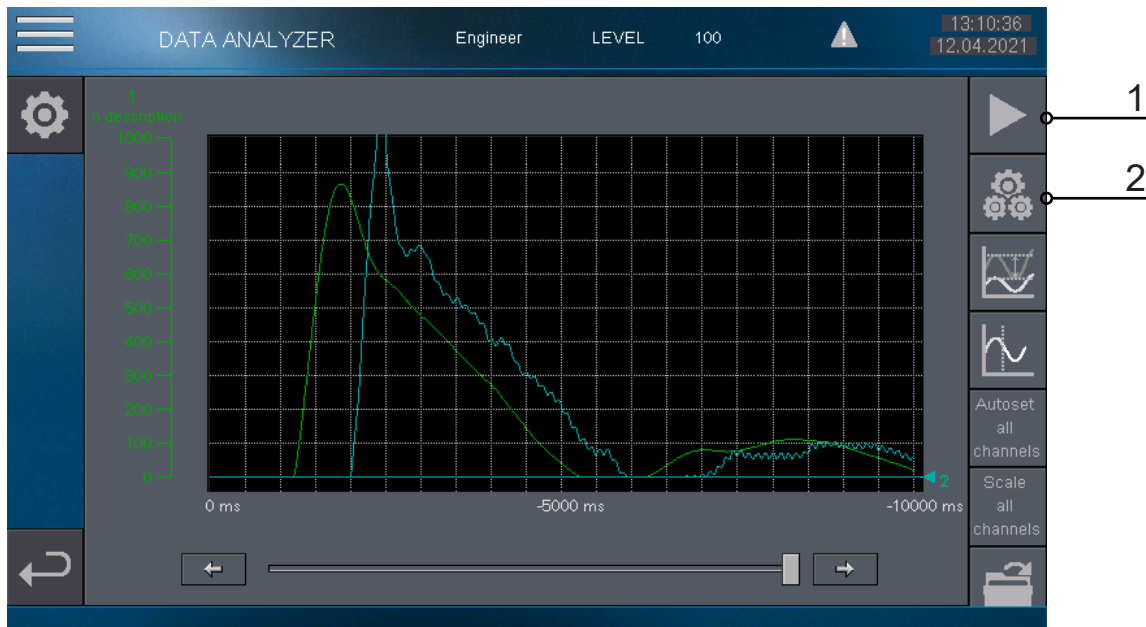

10.9.1 The "Data Analyzer" module allows for real-time data retrieval from the metal detector for diagnosing interference, false alarms, or settings, etc.

10.9.2. (1) The display of data is initiated by pressing the button



10.9.3. (2) Transition to the settings window for channels, scales, and other parameters in the Data Analyzer. In this window, on the left side, you need to select the variable to configure. (access level: 100)

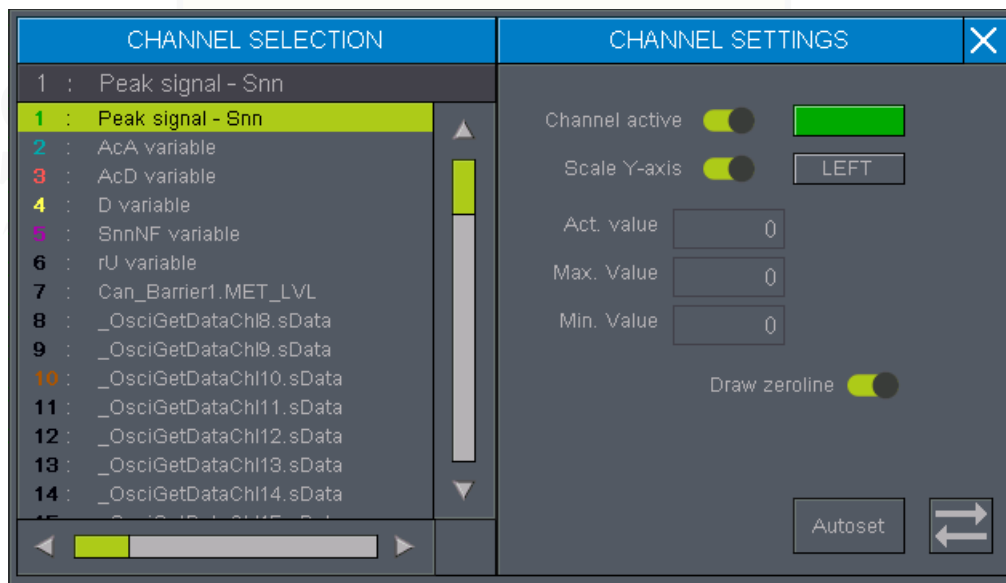

10.9.4. In current window, it is possible to activate/deactivate a channel, determine its color, and set the scale position. By default, the Scale Y-axis is enabled only for the Peak Signal - Snn channel.

10.9.5. To access additional parameters, press the key.

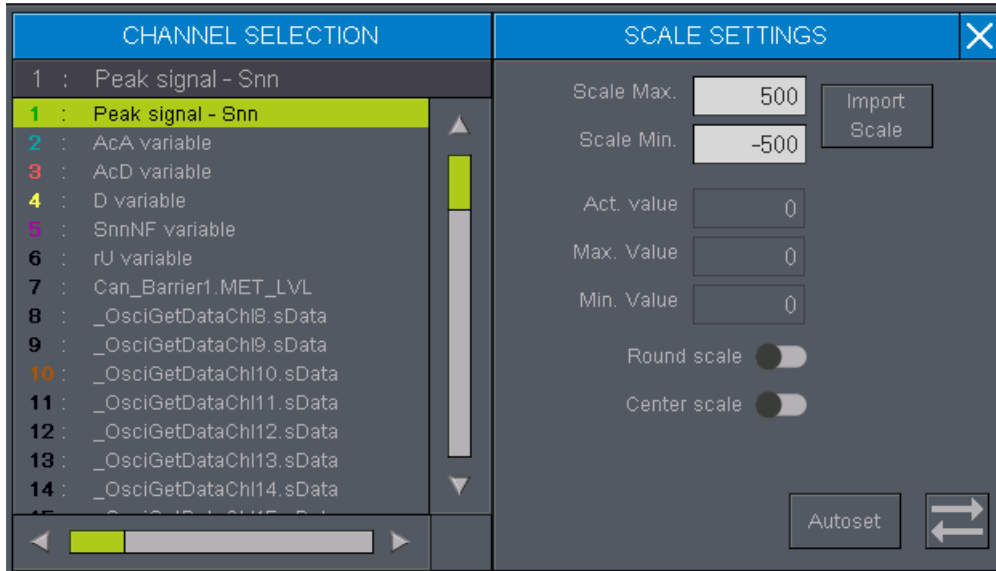

10.9.6. All variables of the metal detector are in one coordinate system and, accordingly, on one scale (default -500...500). Therefore, in the case of changing the parameters Scale Max and Scale Min, this needs to be done for each active channel.

10.9.7. To reflect the changes on the graph, it needs to be restarted by pressing the STOP - START buttons.

SLAVUTYCH
TECHNOLOGY

Barrier

10.10. User Access Control System.

10.10.1. By default, the system reserves 5 users, of which 2 (Service and Slavutych) are intended for debugging and diagnostics by the manufacturer - Slavutych Technology.

10.10.2. The user's access level in the system is displayed at the top of the interface. To authorize a user, press the "LEVEL" button.

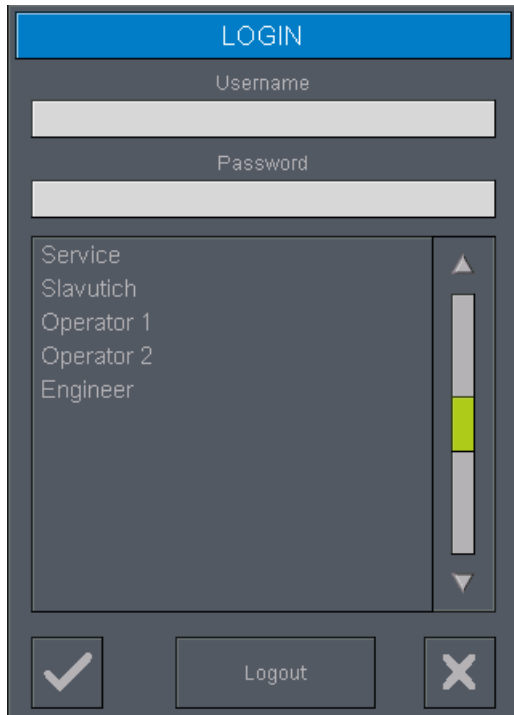

10.10.3. Four profiles are defined for the user:

Operator 1	password: 111
Operator 2	password: 222
Engineer	password: 333
Advanced	password: a444

10.10.4. To log in, select the appropriate profile and enter the password, then press the button. Information about the user and their access level will then be displayed at the top of the main window.

10.10.5. For log out, press the corresponding key.

10.10.6. Create New Users, Delete, Profile Parameter Adjustment is done through the settings window by pressing the button:



- Create a new user
- Change an existing user
- Delete a user

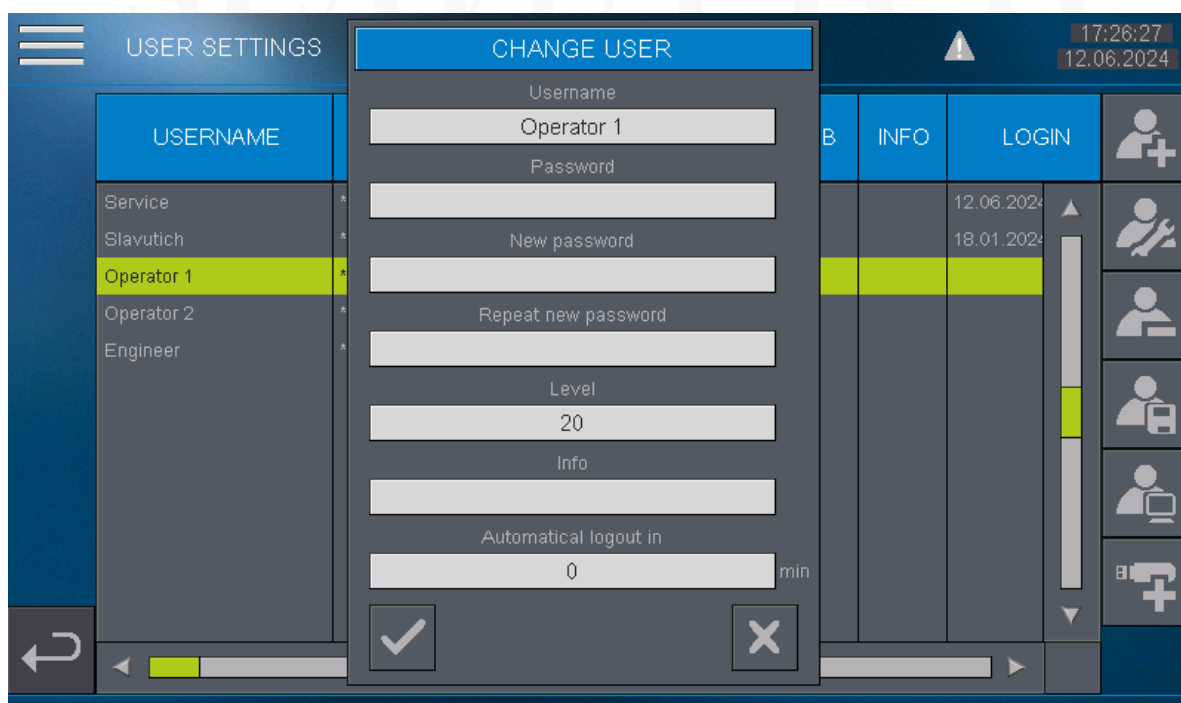

10.10.7. Creating / deleting / modifying users is executed in accordance with the current access level. For instance: a user with access level 20 cannot create a new user with an access level higher than 20.



10.11. Event Log

10.11.1. The event log window is invoked by pressing the button  and looks as follows:



10.11.2. Data export from the event logger to a USB drive is accomplished by pressing the button  with the USB presence symbol  expected to be displayed at the top of the window.

10.11.3. Event log data will be saved in the directory:

/export/eventjournal/

10.12. Main HMI settings

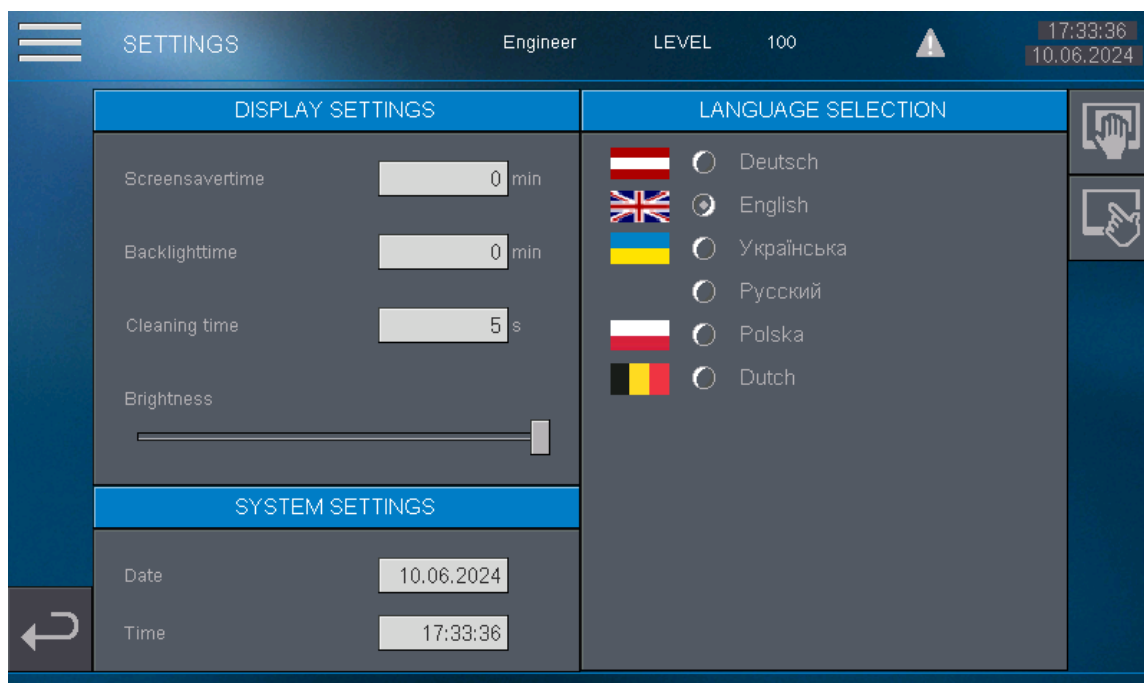

10.11.1. Main HMI settings directly pertain to the interface of module 3B409E, including language switching, date and time settings, display parameters, and touch screen calibration.

10.13. States of the metal detector:

Motion without ore

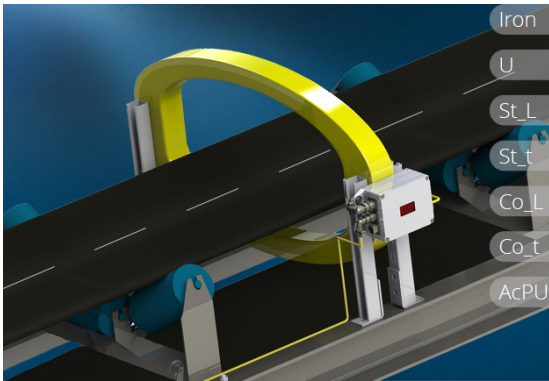

Motion with ore

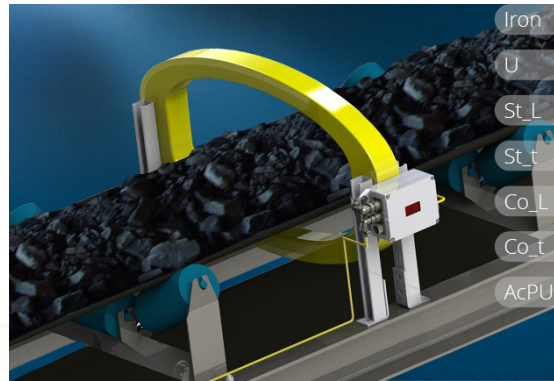

Stopped without ore

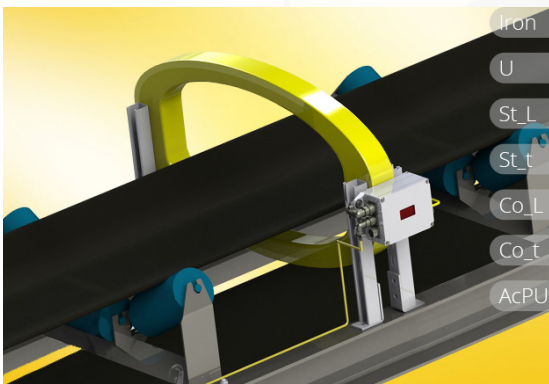

Stopped without ore



Metal detected

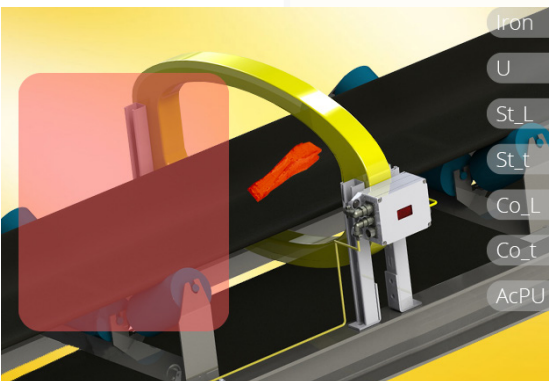

Metal detected in ore

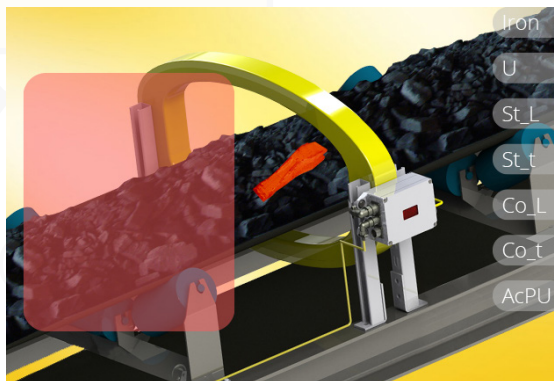

No connection with module 2M409F

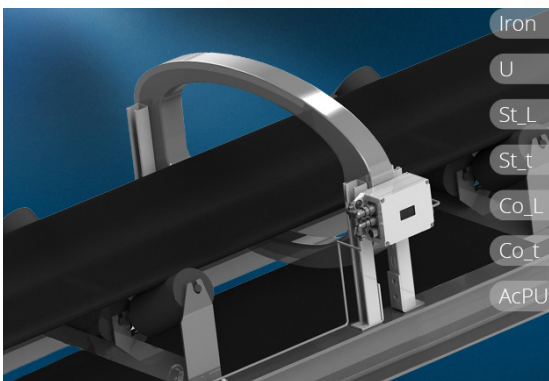

11. Remote access

- 11.1. The built-in VNC server enables connection to the Barrier-409 metal detector using any VNC client. To establish a connection, the metal detector must either be on the same network as the client or have a dedicated IP address for access via the Internet. This approach presents challenges in organizing access to the Barrier metal detector over the Internet, such as for remote support or diagnostics.
- 11.2. An alternative approach to organizing remote access to the Barrier metal detector over the Internet involves using the **Slavutych Remote Access Server**, where the Barrier metal detector itself initiates a connection to the server via a secure VPN link. This setup enables monitoring, diagnostics, and full control of all metal detectors at the facility from any location. To implement this solution, the use of the 3B409E-R control module is required.
- 11.3. To authorize, users need to log in to their account on the server via a browser or mobile app. In case the facility does not have network access near the installed Barrier-409 metal detector, the control module 3B409E-R can optionally be equipped with LTE mobile internet module.
- 11.4. For detailed information on how to use the Remote Access feature, please refer to the Metal Detector Remote Access Manual.

3B409E-R





Name ▾ ↑

Slavutych TEST ● connected 1

Disconnect Slavutych T...

Kazakh_DF1 ● connected 1

Disconnect Slavutych T...

Kazakh_DF2 ● connected 1

Disconnect Slavutych T...

PL_Śląsk ● connected 1

Disconnect Slavutych T...

SA_TEST Unit ● connected 1

Disconnect Slavutych T...

VPN Connected to Slavutych TEST Details



VPN

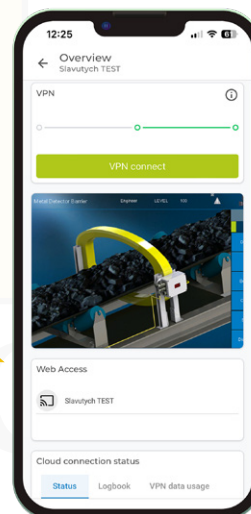
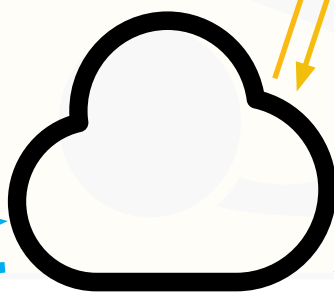

12. Factory settings

Table 6.

Name	Value
Detection threshold (by size)	300
Detector signal duration (by lenght)	0
Splice threshold	1500
Splice duration	3
Advanced splice processing algorithm L-2P	0
Number of belt clip detectors	1
Lower disable range 0	4000
Upper disable range 0	4001
Lower disable range 1	4010
Upper disable range1	4011
Lower disable range 2	4020
Upper disable range 2	4021
Lower disable range 3	-999
Upper disable range 3	-999
Threshold at Conveyor Start-up	0300
Duration of threshold at Conveyor Start-up	1
Start-up Calibration Time	15
Ore tuning parameter	470
Threshold for rU	50
Algorithm number for welding protection	0
RS-485 speed	19_2
RS-485 adress	1

13. Marking, Sealing, and Packaging

- 13.1. The 2M409F conversion module and the / 3B409E control module of the metal detector are equipped with the manufacturer's standard nameplate. The nameplate indicates the model and number of the metal detector.
- 13.2. The two screws securing the 2M409F cover are equipped with seals and are protected with a sealing compound.
- 13.3. All seals must have an imprint.
- 13.4. The metal detector, along with its accessories, is packed in a transport container.

13.1. Storage Principles

- 13.1.1. The metal detector that has arrived at the warehouse and is intended for operation either immediately or within 24 months from the date of receipt can remain in the transport packaging and be stored in its packed form.
- 13.1.2. Metal detectors intended for long-term storage are kept in a storage box at ambient temperatures ranging from -50°C to $+50^{\circ}\text{C}$ and relative humidity up to 98% (up to 35°C). The storage room should be free from dust, acid and base vapors, and gases causing corrosion.

13.2. Preservation

- 13.2.1. If it is anticipated that a metal detector that has already been in use will be inactive for an extended period, it is recommended to carry out its conservation.
- 13.2.2. Before preservation, the metal detector and its associated equipment should be cleaned of dirt and dust and dried under laboratory conditions for 2 days.
- 13.2.3. Packing of the metal detector should take place once the temperature of the metal detector and the room's temperature, where packing is done, are completely aligned.
- 13.2.4. Before placing the detector in the box, it should be placed in a polyethylene cover.
- 13.2.5. To cushion, the space between the walls, bottom, and lid of the box and the external surfaces of the box should be filled with a shock-absorbing material to seal.

13.3. Transport Conditions.

- 13.3.1. Transport of the metal detector in transport packaging can be done using any means of transport at ambient temperatures ranging from -50°C to $+60^{\circ}\text{C}$. If the metal detector was stored in a factory package, it should be transported in this package.
- 13.3.2. During transport and storage, it is essential to prevent the metal detector from direct exposure to atmospheric precipitation: rain, snow, etc. Throwing and overturning the crate is not permitted.

14. Troubleshooting

14.1. Metal Detector triggering due to ore effect

- 14.1.1. Log in using the Engineer account (default password 333) and open the Data Analyzer window.
- 14.1.2. Ensure that the scale for signals **Snn**, **AcA** is set identically. (see 10.7)
- 14.1.3. Start plotting the signals.
- 14.1.4. During the passage of ore, the **Snn** signal (green) should tend towards zero. In case of significant deviation, start Auto ore tuning 10.3.

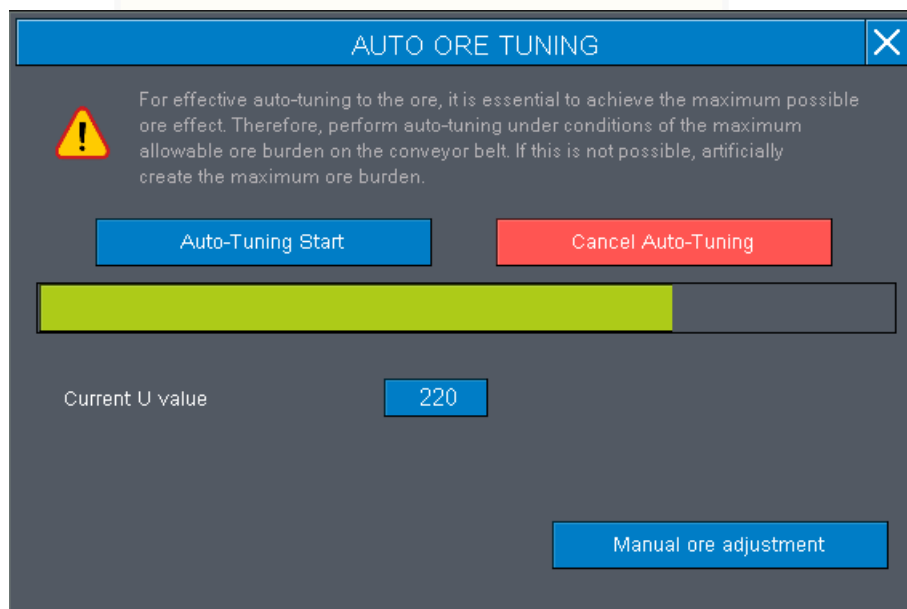

14.2. False Triggering

In the event of a false triggering, perform the following actions to determine the cause:

14.2.1. Incorrect Distance to Metal.

Place a test metal, and after it is detected, measure the actual distance to the metal and verify that it matches the indicated value (in decimeters) on module 2M409F and the equipped search location at the facility.

14.2.2. Excessive Sensitivity

- 1) Log in using the Engineer account (default password 333) and open the Data Analyzer window and start plotting the signals and monitor the **Snn** signal (green).
- 2) Determine the maximum value of **Snn**.
- 3) For the highest sensitivity of the Barrier metal detector, the detection threshold **Iron** should be at least 30%-50% higher than the maximum **Snn** value.
- 4) For normal sensitivity, it is sufficient to set the detection threshold **Iron** 2-3 times higher than maximum **Snn** value.



SLAVUTYCH
TECHNOLOGY

Slavutych Technology Metal Detector Barrier-409

Annexes to the User Manual
Version 4.13 - English

06.10.2025

Anneks 1. Metal Detector Modules

Annex 1.1. Conveyor search coil 1D204 with mounted conversion module 2M409F

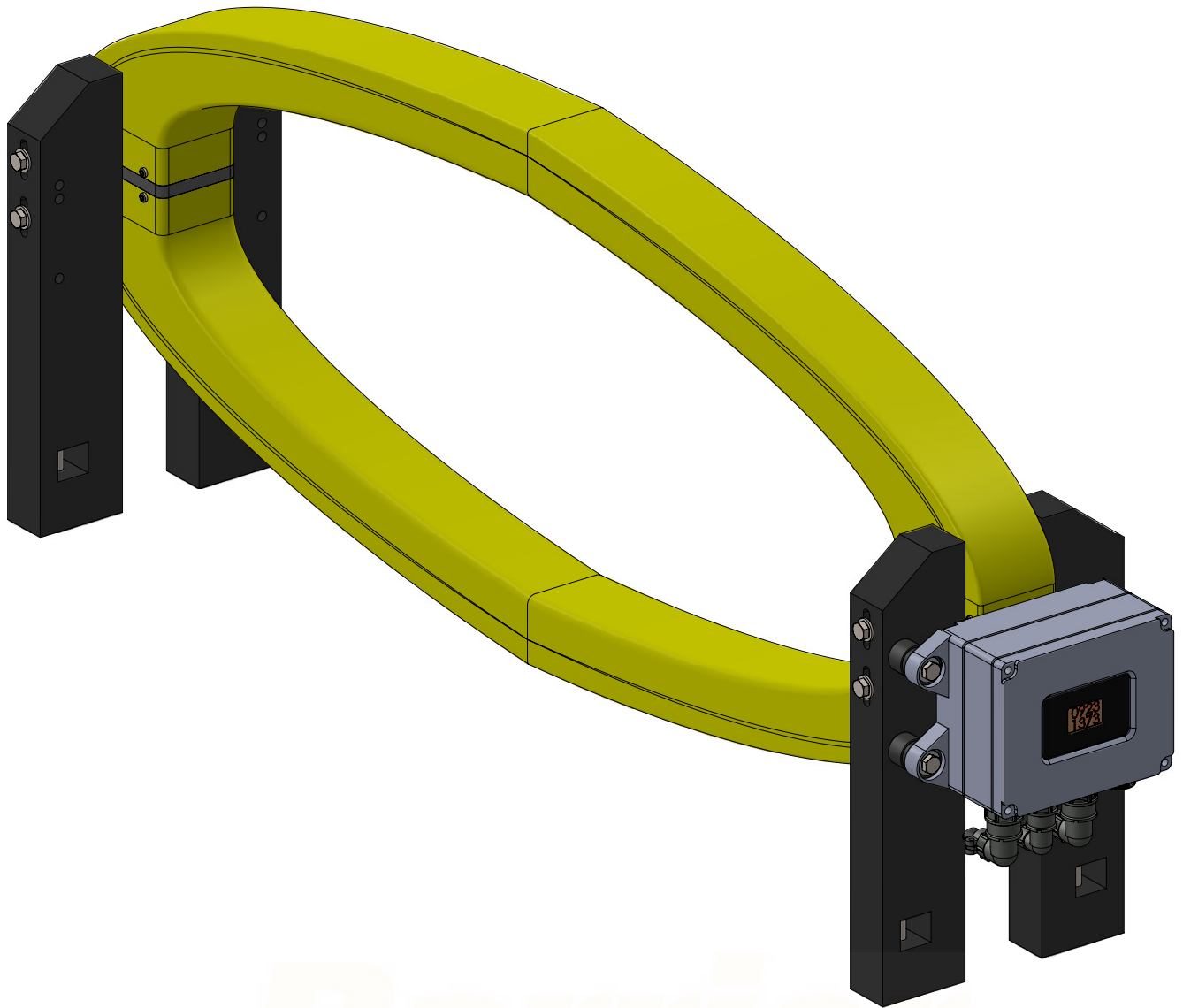

Barrier

Annex 1.2. Belt clip detector module 1C503

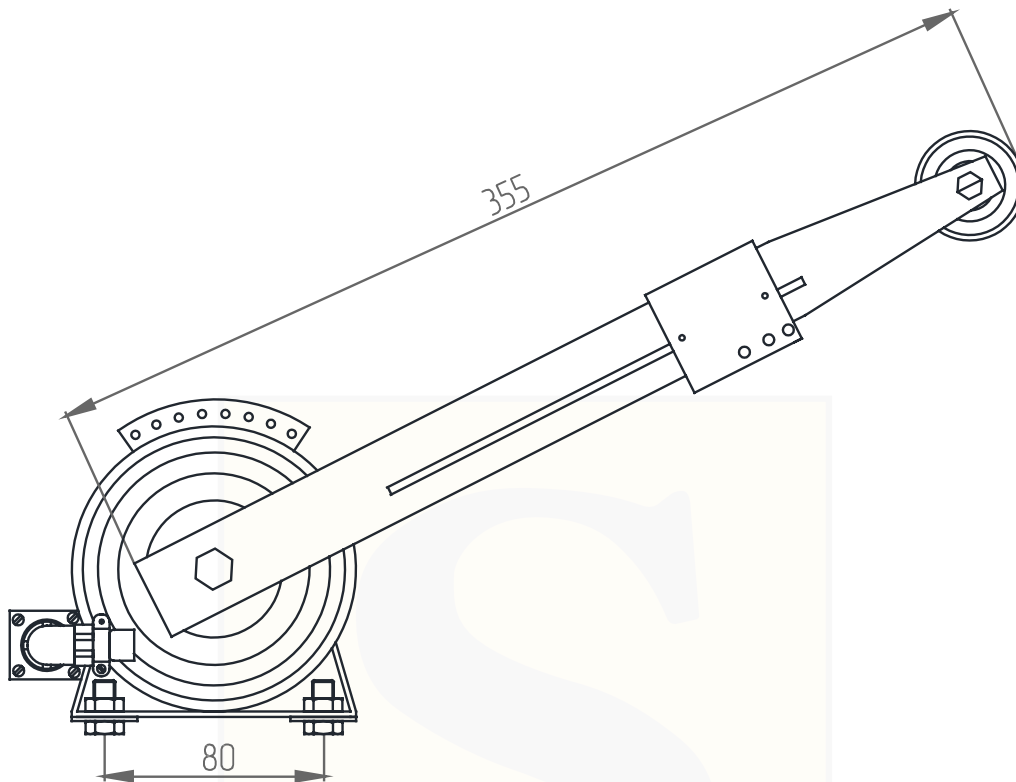

Installation Notes:

- 1) Clip detector is installed at a distance of up to 1-2 meters from the search coil 1D204, in the direction opposite to the movement of the belt, and is connected to 2M409F / 2M409A with a standard cable IF4.851.139-04 (if Junction Box 1C008 is not used).
- 2) Belt clip detector 1C503 should be installed so that at the maximum possible transverse displacement of the belt, its tip is in contact with the belt.
- 3) At the belt junctions, if necessary, install metal clamps parallel to the seam line of the belt from the middle of the belt to its nearest edge, so that the detector's tip passes through the center of the clamp line.

Example of a recommended support for installing 1C503.

Manufacture one support for the Belt clip detector 1C503 according to this drawing.

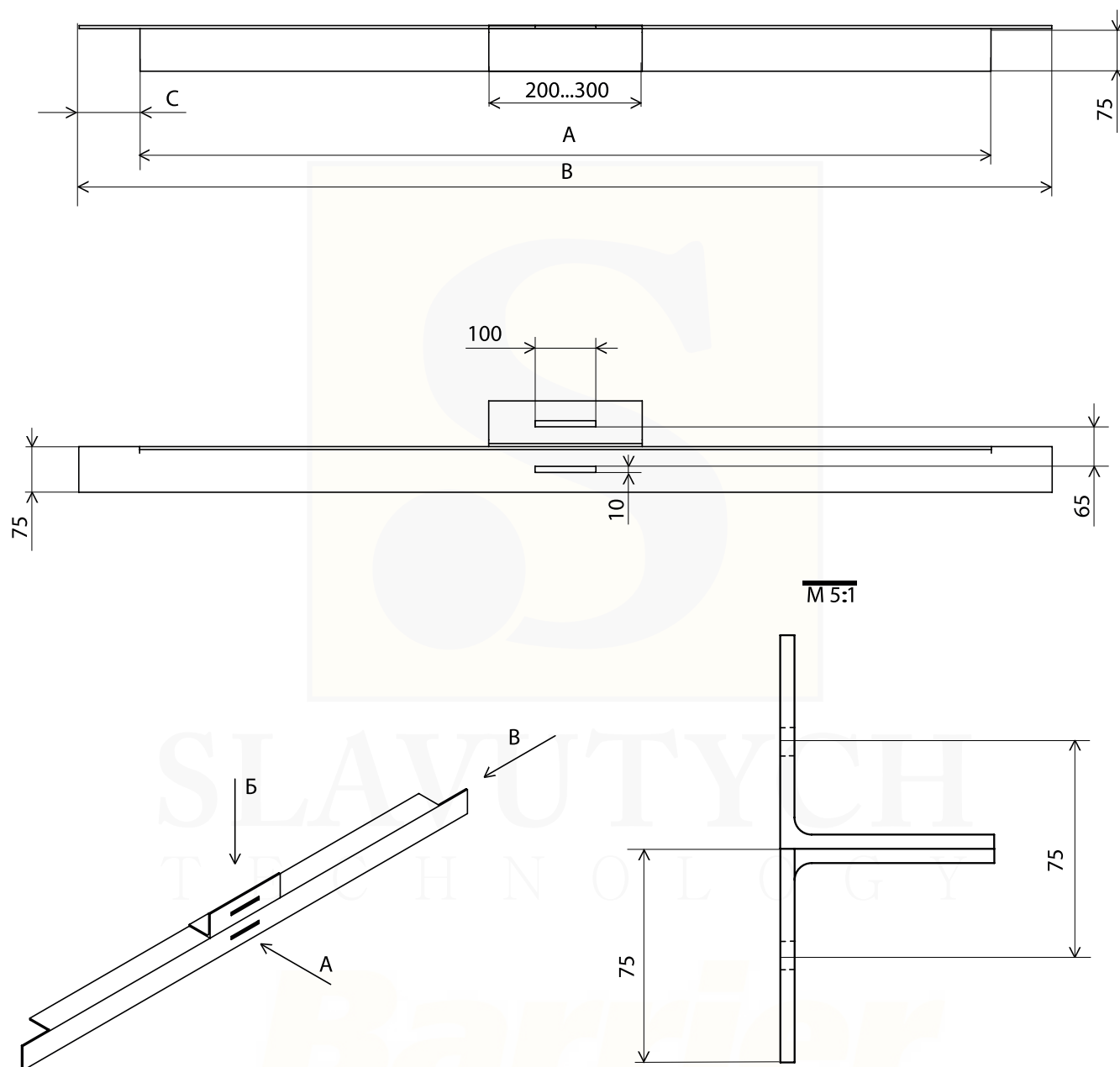

Annex 1.3. Belt clip detector module 1C505

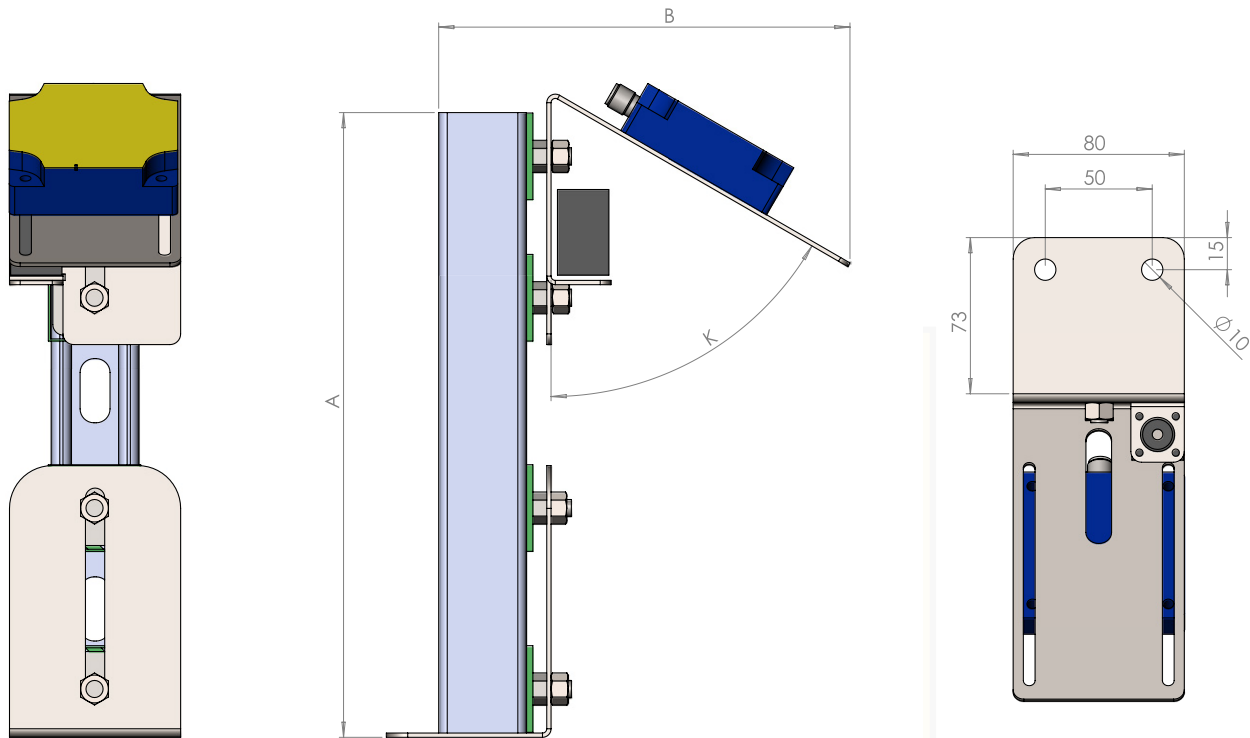

Installation notes:

- 1) Clip detector to be installed from 50 to 100mm behind first idler before coils.
- 2) Drill holes in conveyor stringer using mounting flange as a template. Mount Belt clip detector on stringer using machine screws.
- 3) Adjust the belt clip detector horizontally and vertically for the 20...30mm maximum distance from the conveyor belt. Detector must be installed and adjusted so that it is parallel to the belt in both direction.
- 4) The joint of the steel-cord belt should be marked with metal clip(s) in such a way as to ensure their detection.

Annex 1.4. Metal position module 1C301

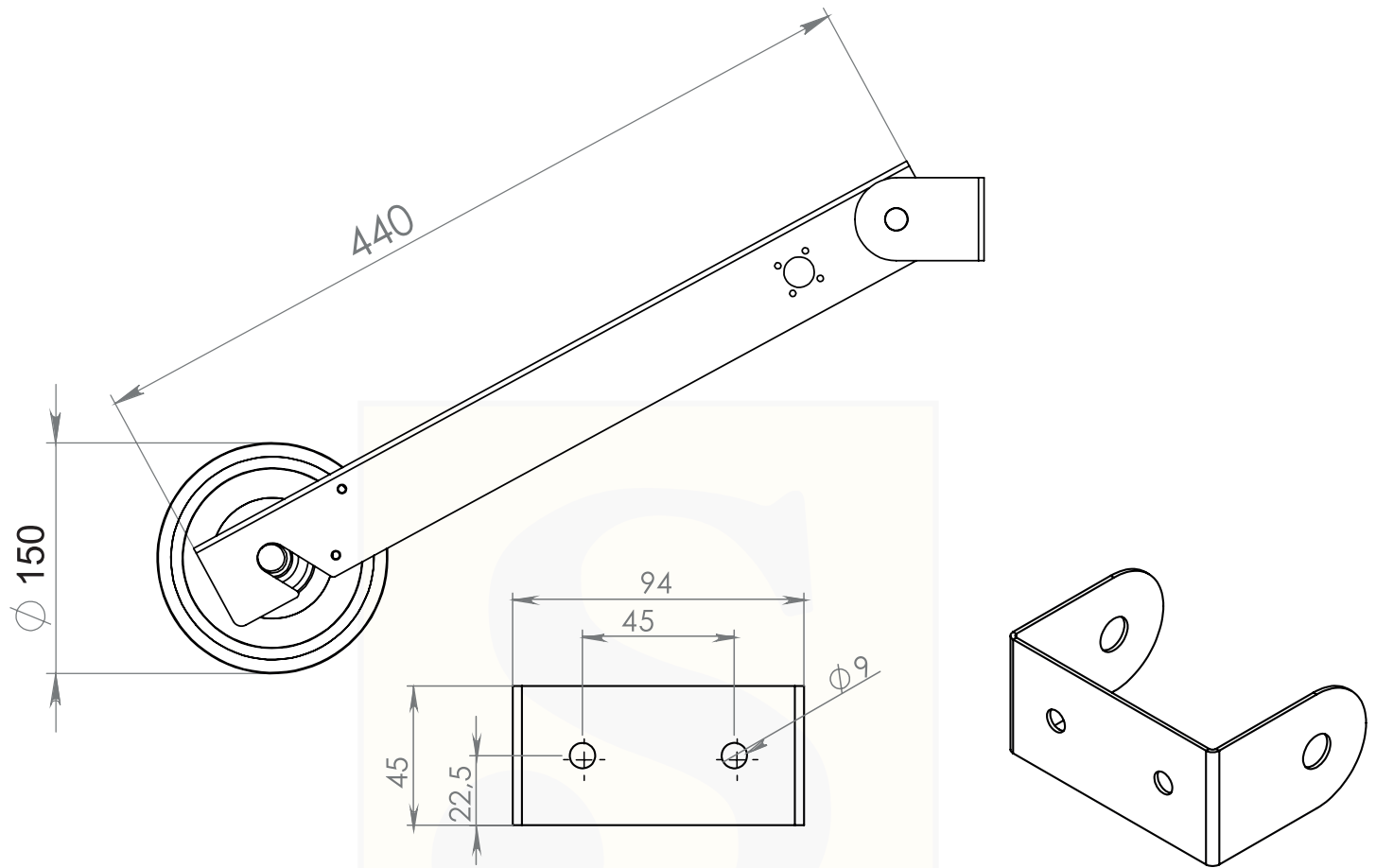

Annex 1.5. Conversion module 2M409A / 2M409F

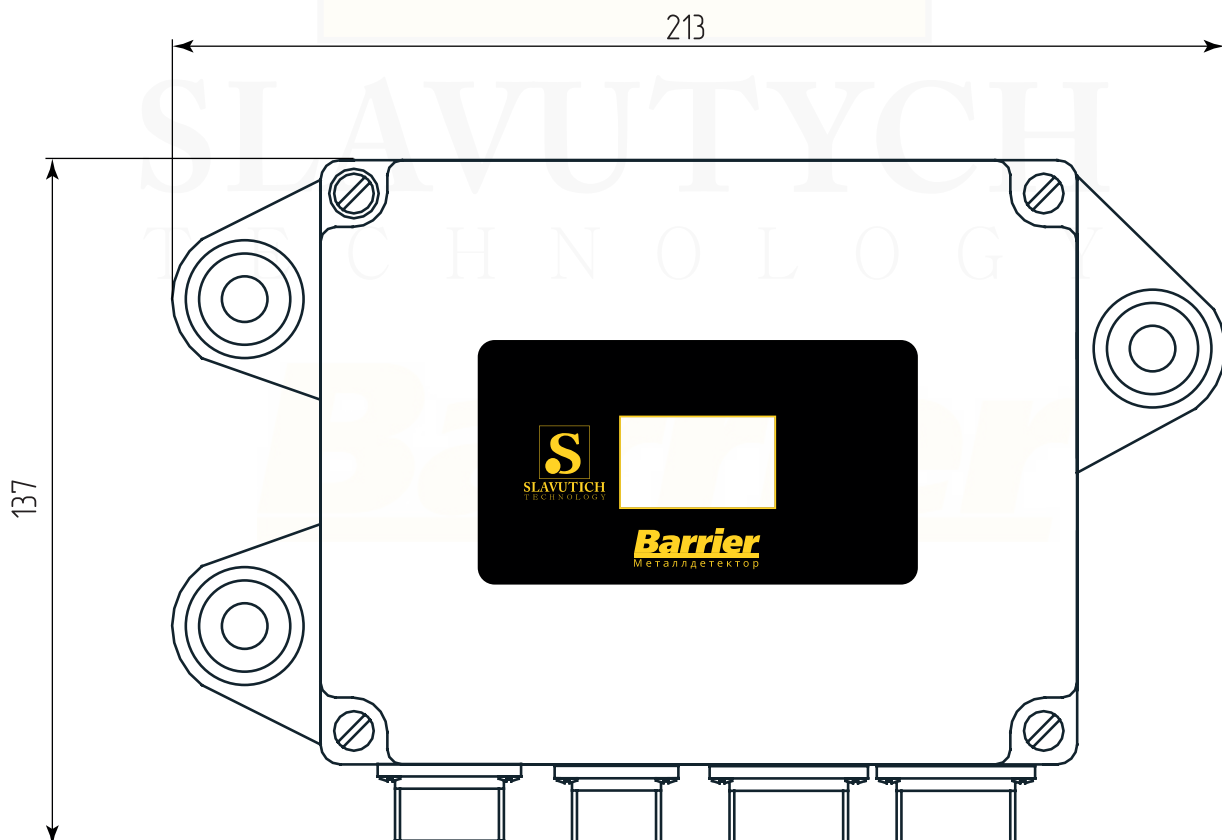

Annex 1.6. Control module 3B409E

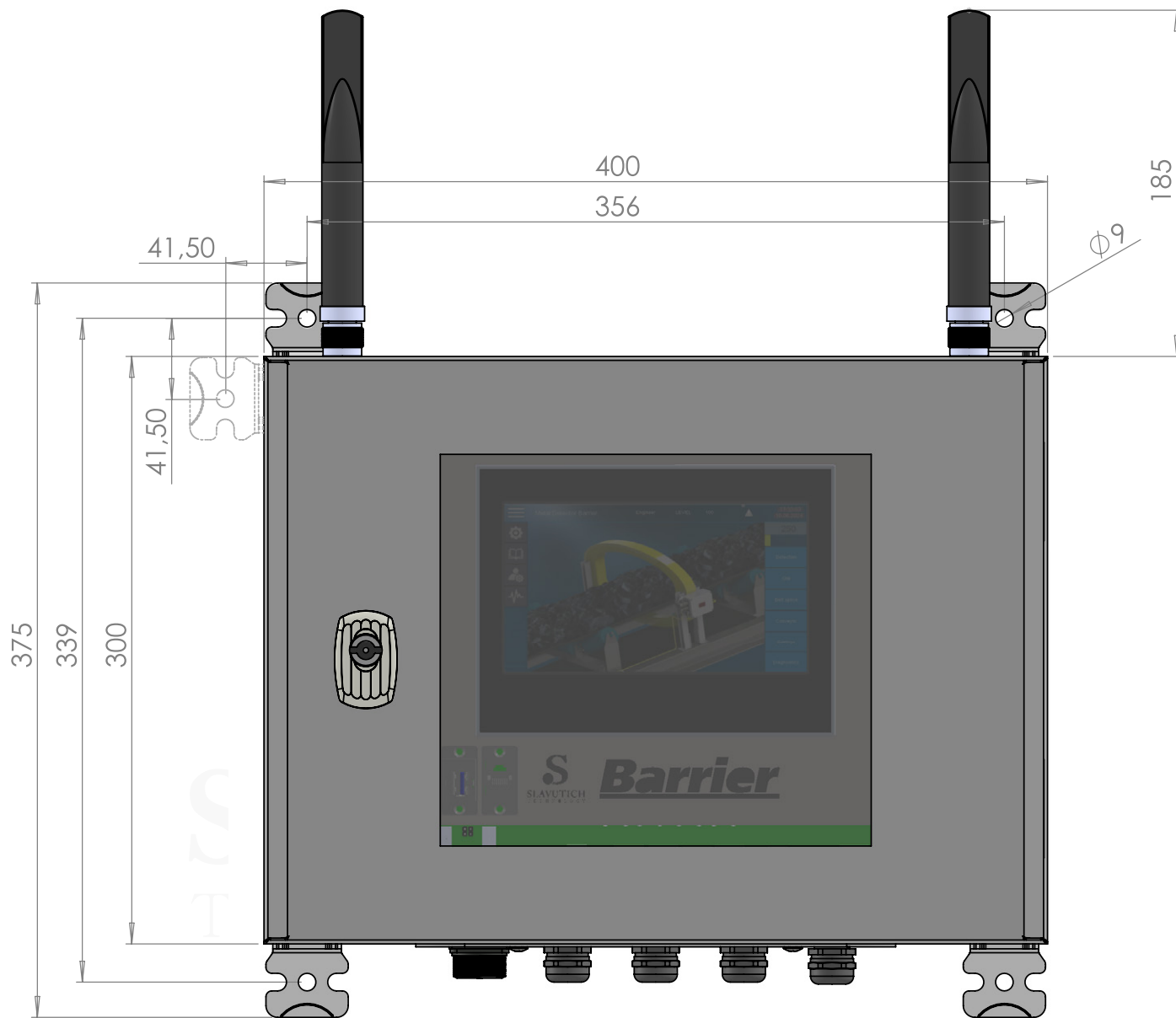

Antennas only for 3B409-R modification

Annex 2. Connection and wiring schematics

Annex 2.1. General connection of "Barrier-409" Metal Detector

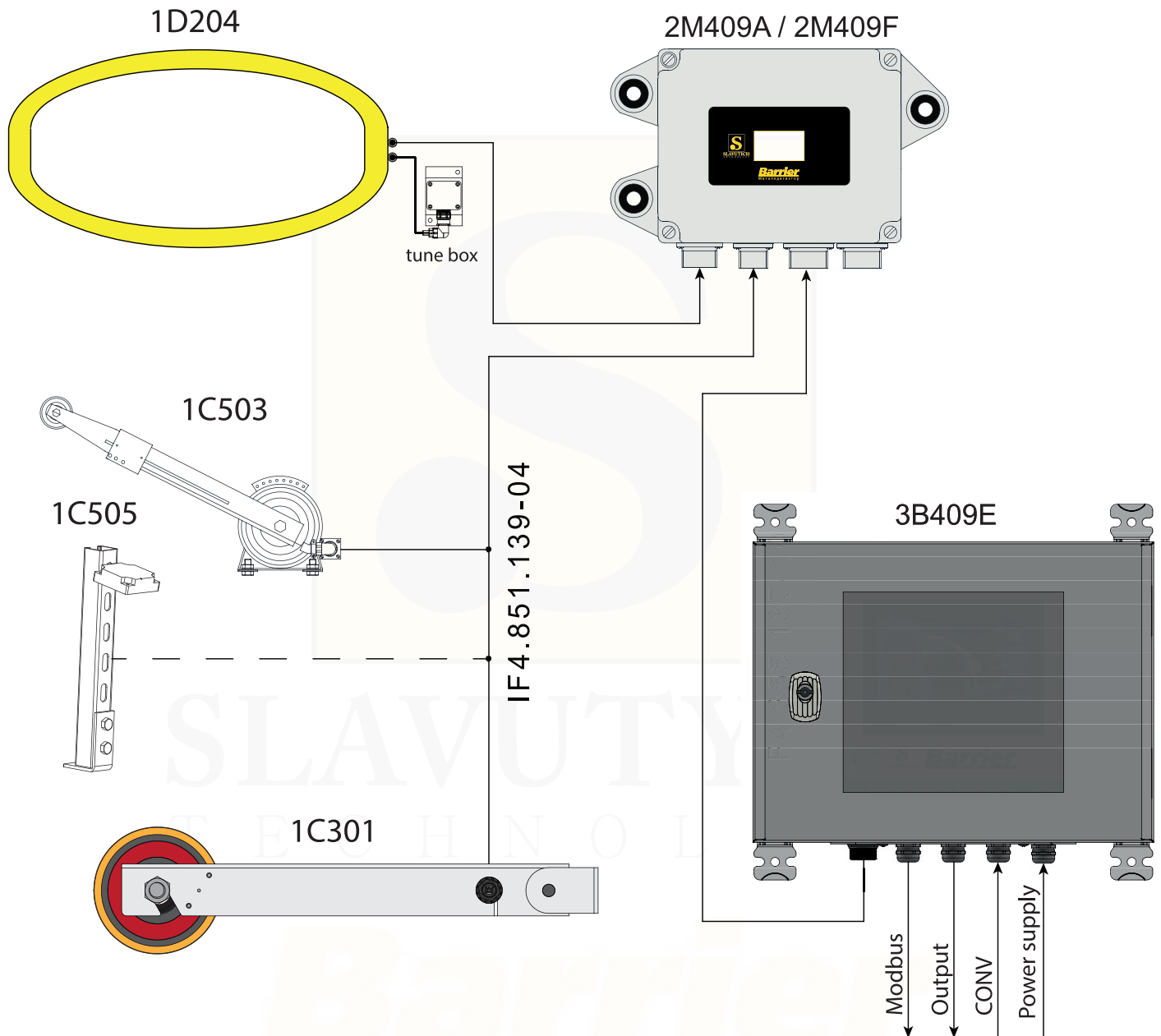

Annex 2.2. Connection diagram of the "Barrier-409" Metal Detector Modules. Variant 1

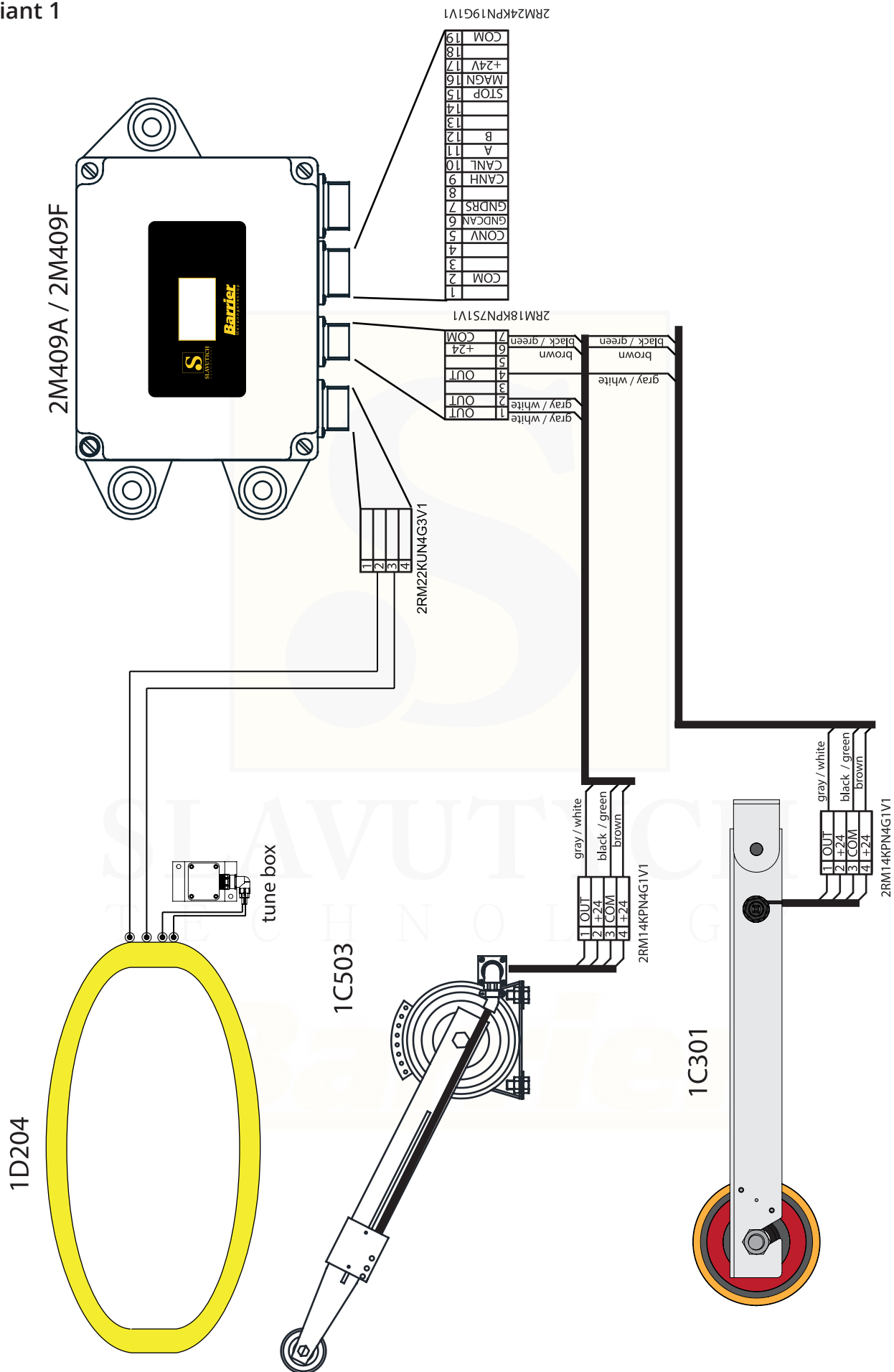

Annex 2.3. Full connection diagram of the "Barrier-409" Metal Detector Modules with Junction Box 1C008.

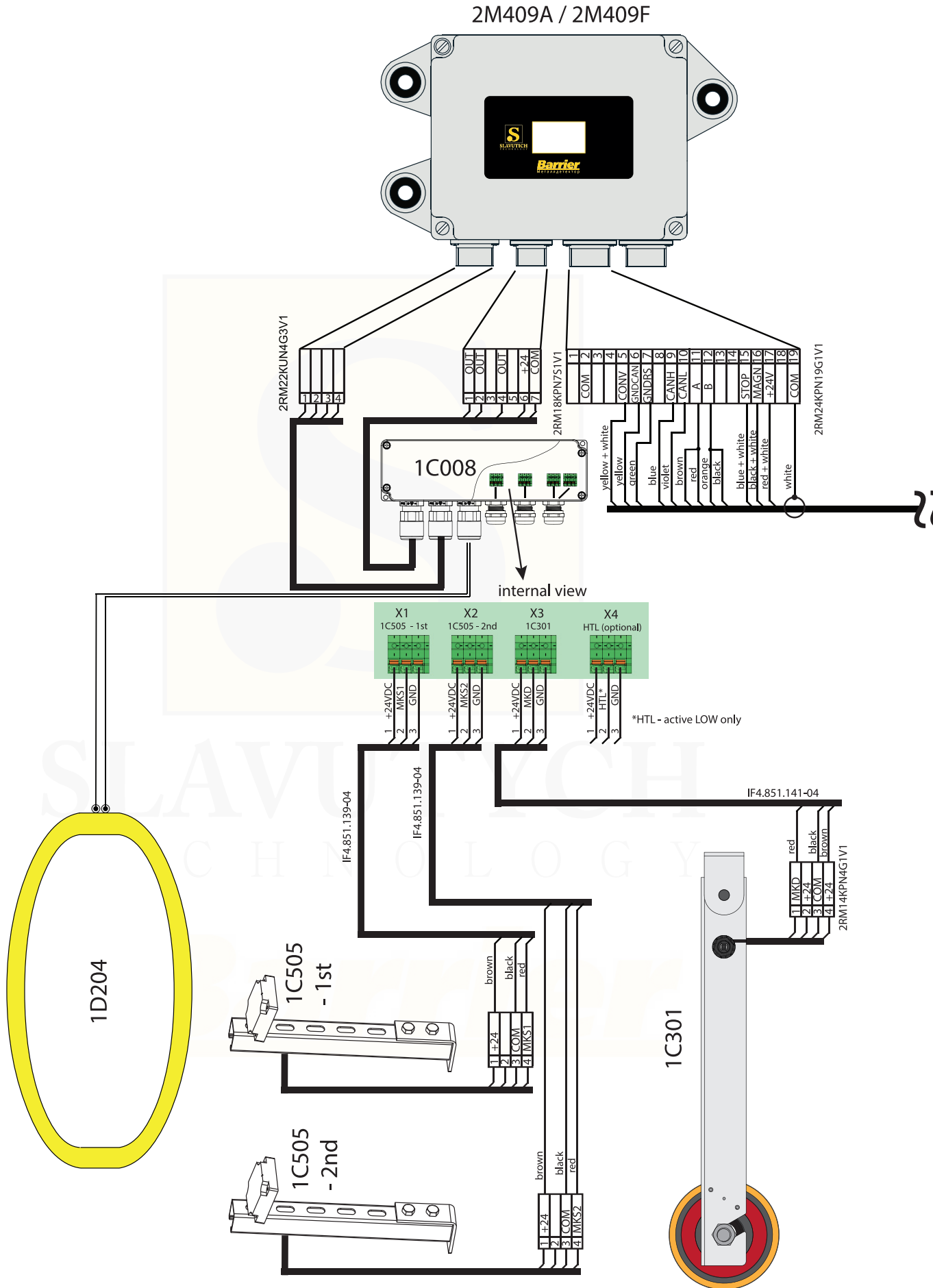

3B409E

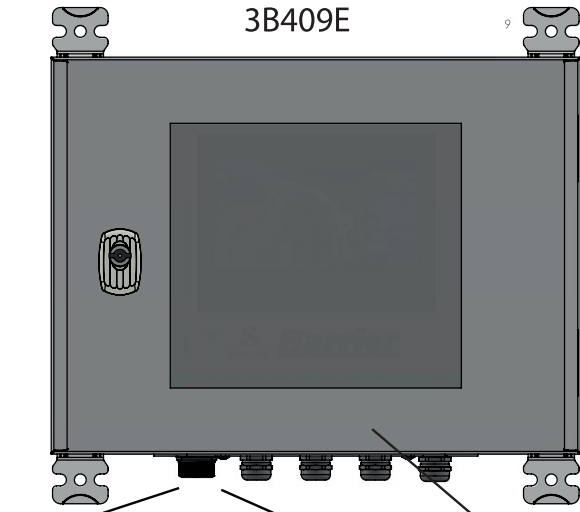

1	
2	
3	GND/RS
4	GND/CAN
5	CONV
6	A
7	B
8	
9	CANH
10	CANL
11	A
12	B
13	
14	STOP
15	MAGN
16	+24V
17	
18	COM
19	

2RM24KPN1951V1

- yellow
- green
- yellow + white
- brown
- black
- blue
- violet
- red
- orange
- blue + white
- black + white
- red + white
- white

IF4.855.137-10

internal view

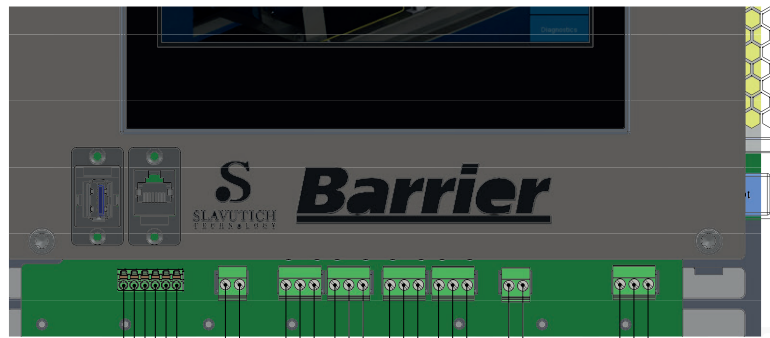

- A
- B
- GND/RS
- GND/RS
- +24VDC
- GND
- METAL NC1
- METAL C1
- METAL NO1
- METAL NC2
- METAL C2
- METAL NO2
- ADDITIONAL NC1
- ADDITIONAL C1
- ADDITIONAL NO1
- ADDITIONAL NC2
- ADDITIONAL C2
- ADDITIONAL NO2
- CONV1
- CONV2
- 220VAC
- GROUND
- 220VAC

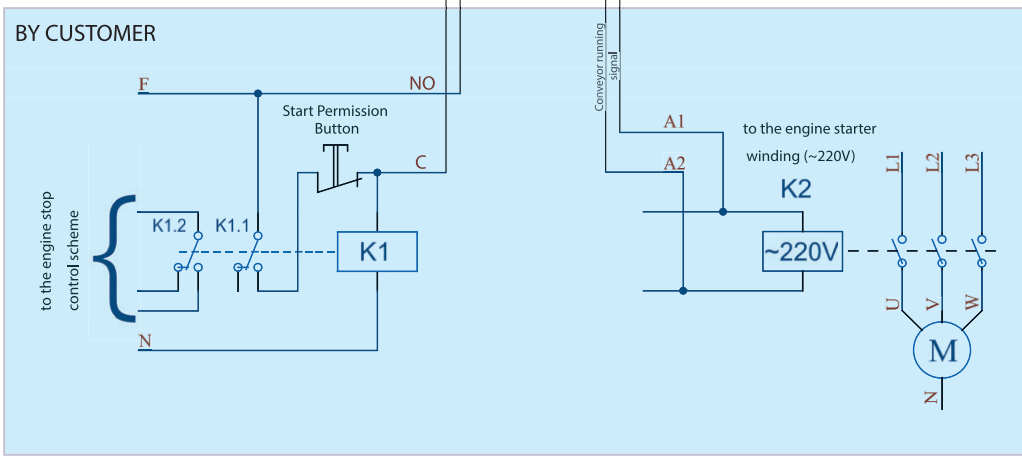

Annex 2.4. External Connections to the Control Module 3B409E

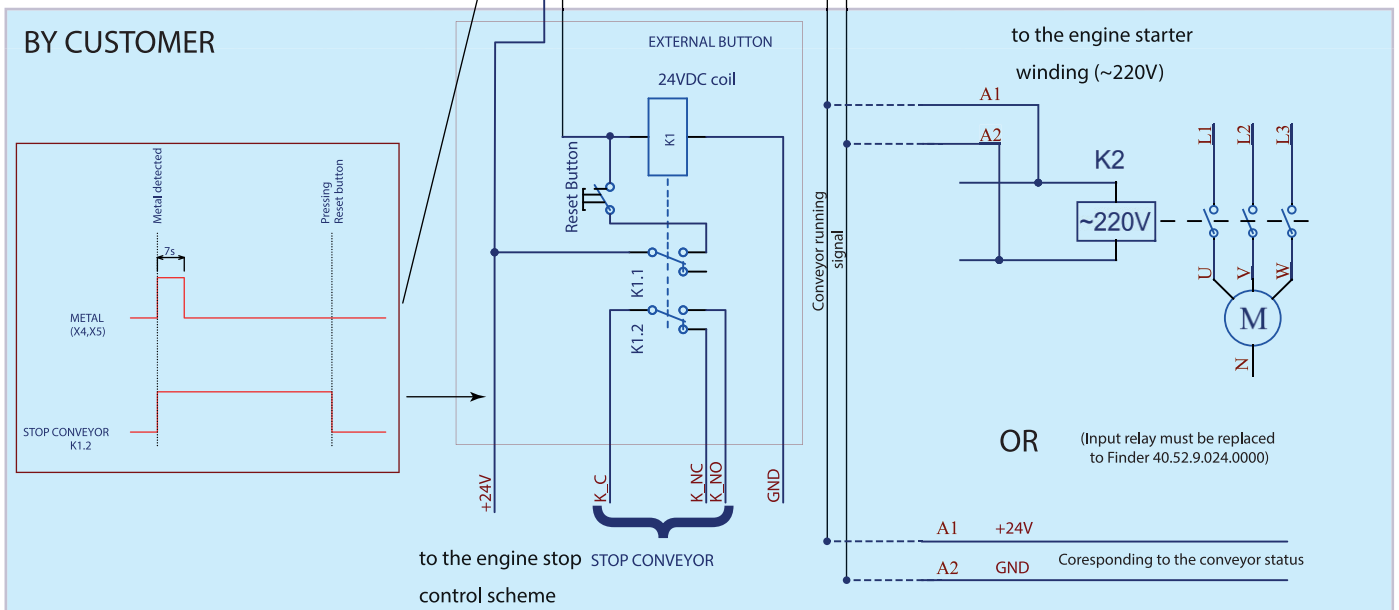
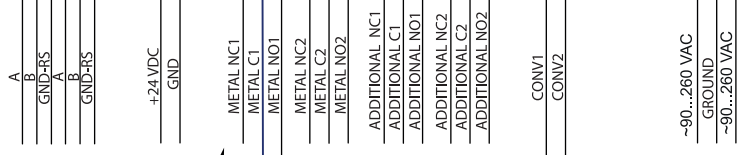
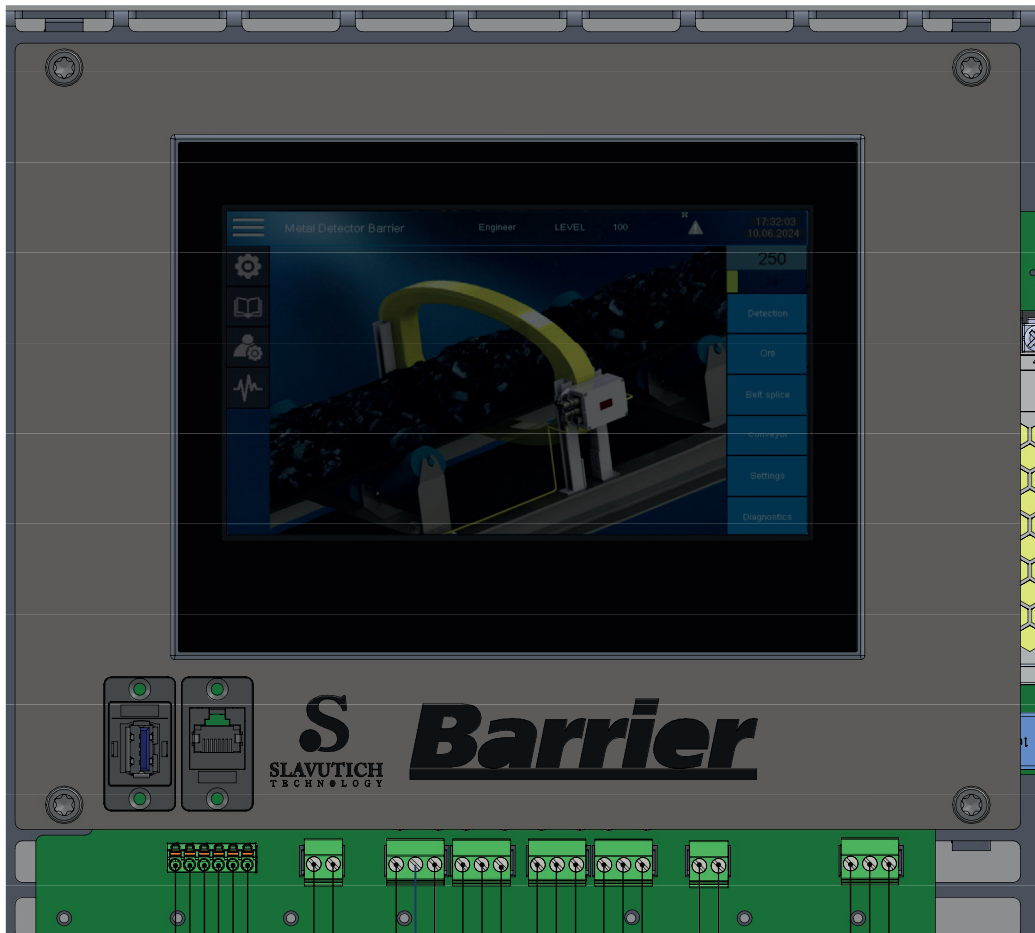

Annex 2.5. Description for external connections to the Control Module 3B409E

1) Upon detecting metal, the metal detector generates a METAL signal (X4,X5) with a duration of 7 seconds to halt the conveyor. This signal can be utilized by the enterprise's SCADA system, or if direct conveyor control is required, the customer can implement a circuit with a button and an additional relay connected in a self-latching configuration.

2) For the metal detector to operate, an input signal CONV 220 VAC (X8) must be supplied, indicating that the conveyor is running. Upon detecting metal, the metal detector stops the conveyor and switches to detection mode only after the conveyor restarts (CONV signal).

If a 24VDC signal is required, the input relay (RE3 Annex 2.8) of module 3B409E must be replaced from Finder 40.52.8.230.000 to Finder 40.52.9.024.0000 (the relay is mounted on a panel).

3) The standard power supply for the metal detector is 220V, although, if necessary, the Barrier metal detector can be powered by 24VDC (X1)

SLAVUTYCH
TECHNOLOGY

Barrier

Annex 2.6. CONV signal emulation

In the event of metal detection the metal detector stops the conveyor to allow an operator to remove the tramp metal. It is also possible to control external equipment such as electromagnets or to transmit a metal detection signal without stopping the conveyor. For such modes emulation of the CONV input signal corresponding to the conveyor status is required. Supply 110 VAC 220 VAC or 24 VDC depending on the input relay through the second contact set of the METAL relay.

When metal is detected this contact set opens for 7 seconds and the CONV signal becomes inactive which emulates a conveyor stop.



SLAVUTYCH
T E C H N O L O G Y

Barrier

Annex 2.7. CONV signal emulation via VAC power supply

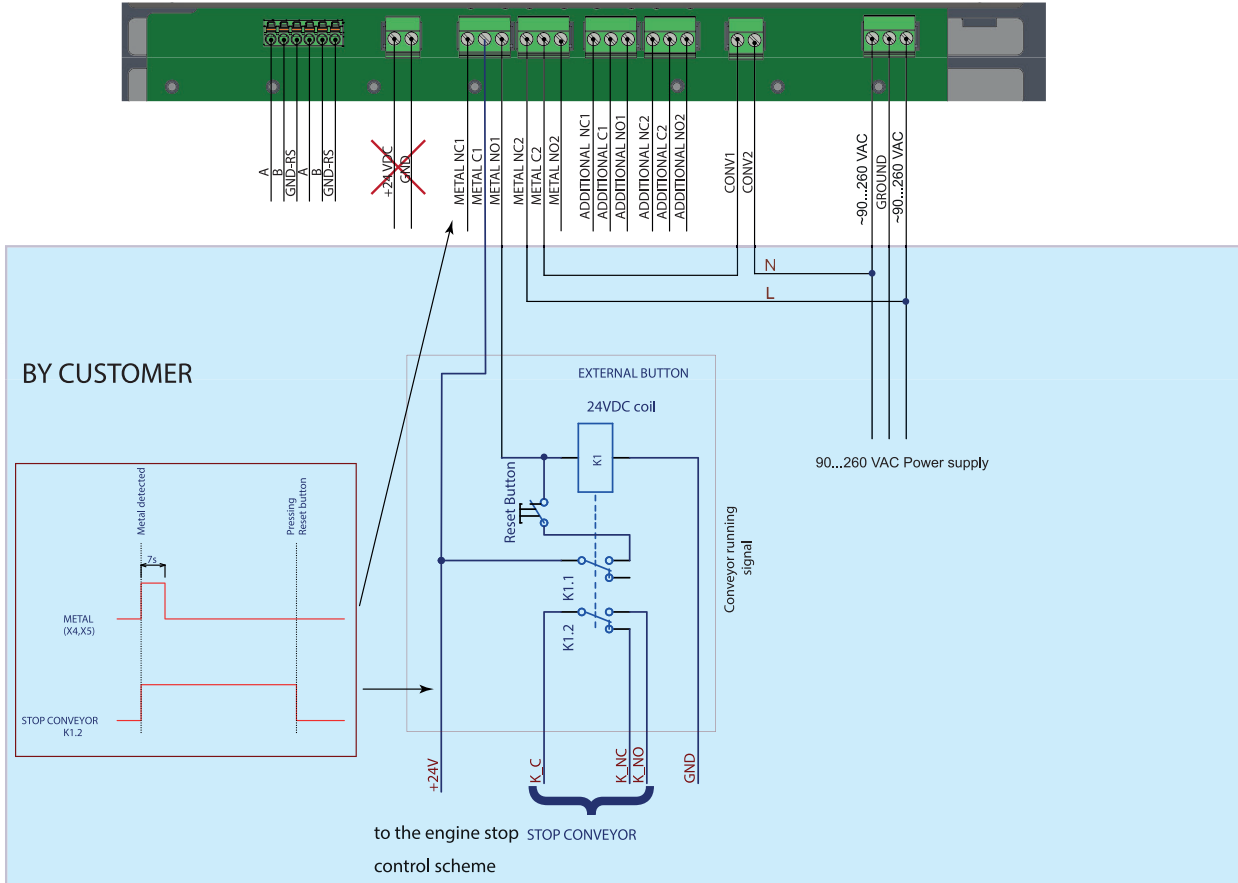

Annex 2.8. CONV signal emulation via 24 VDC power supply

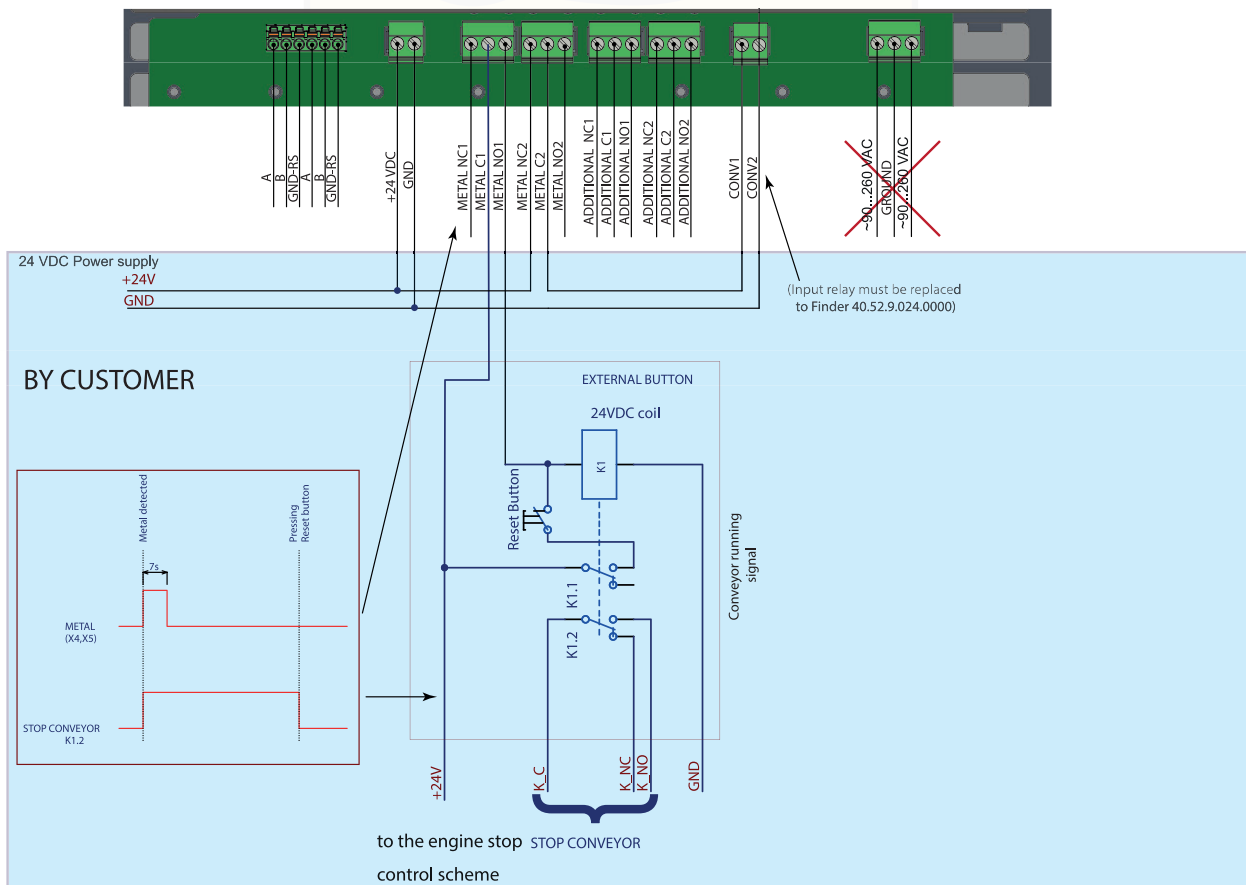

Annex 2.9. Internal schematic Diagram of Control Module 3B409E

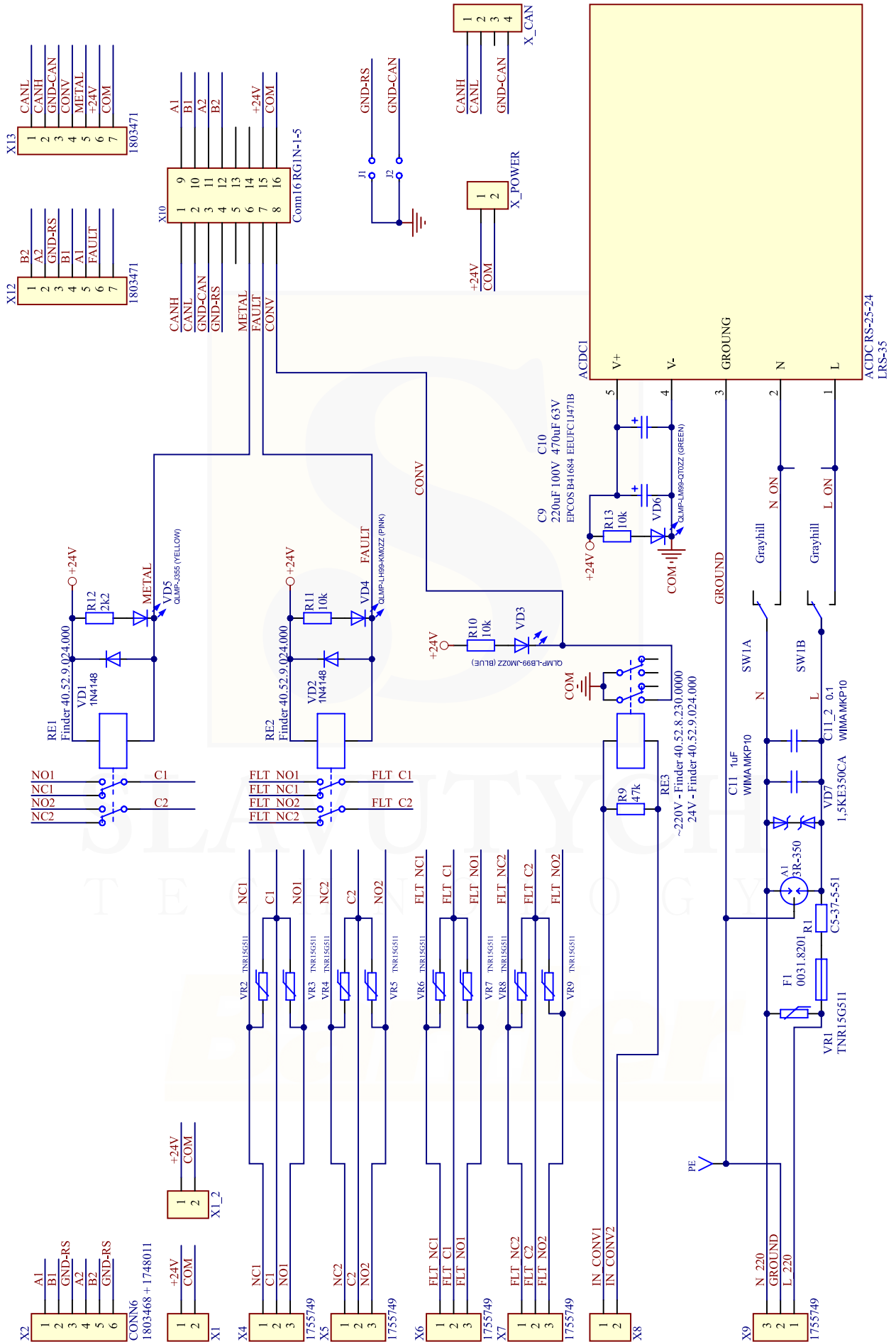



SLAVUTYCH
TECHNOLOGY

Slavutych Technology Metal Detector Barrier-409

Metal Detector Installation
Version 4.1.3 - English

06.10.2025

WARNING The metal detector coil installation must be carried out carefully to avoid damage to the coil especially for coils intended for belts wider than 1800 mm.

- STEP 1 Remove the coil from the wooden crate evenly without lifting it by the yellow frame
- STEP 2 Unscrew 7 pcs M6 bolts on each side of the coil (for coils smaller than 2000mm BW unscrew 4 pcs on each side)

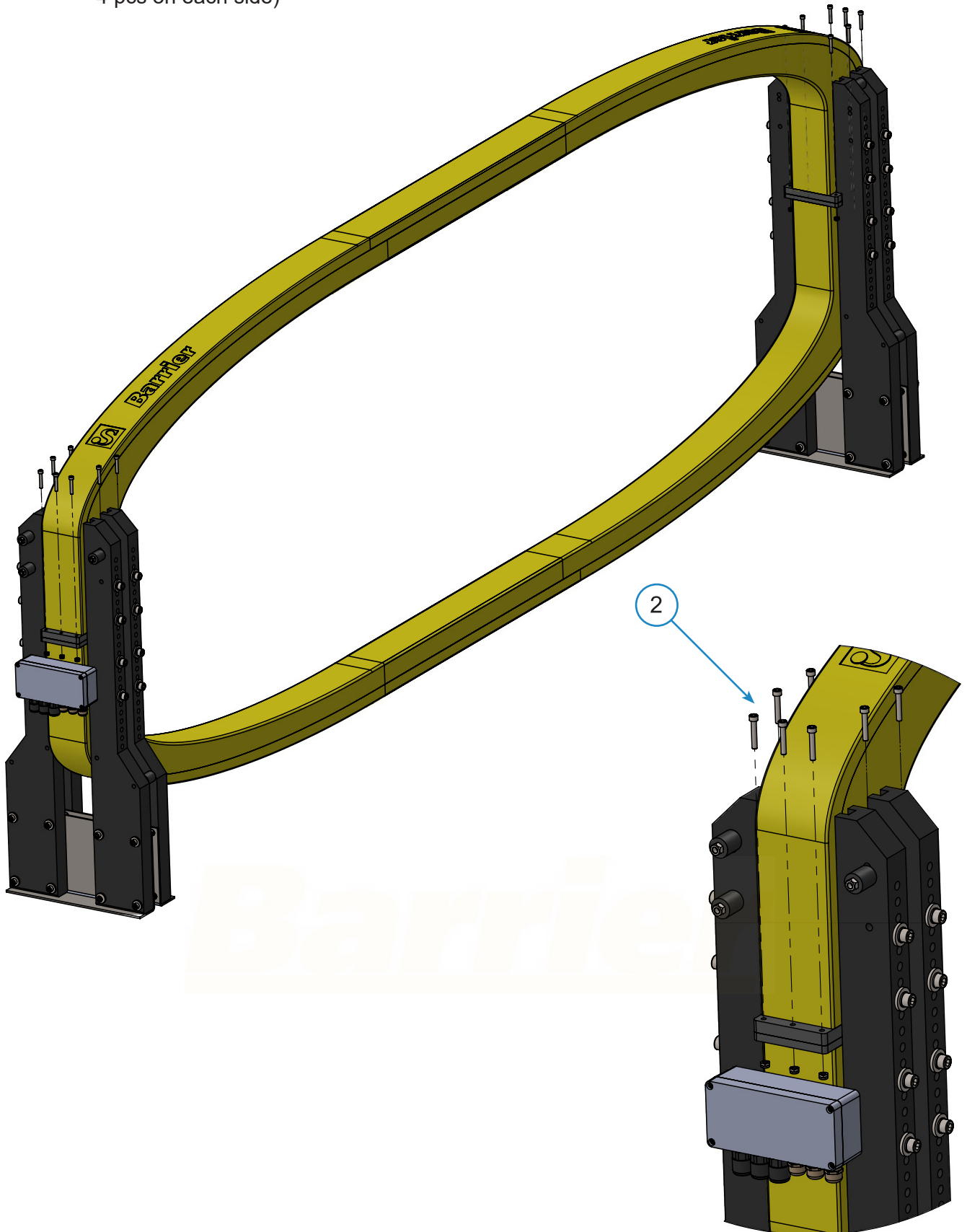

STEP 3

Carefully place the coil under the conveyor belt. If necessary temporarily move one roller idler.

Unscrew 4 pcs M10 bolts on each side of the coil that secure the upper frame section. (For coils smaller than 2000 mm BW unscrew 2 pcs M8 bolts on each side.)

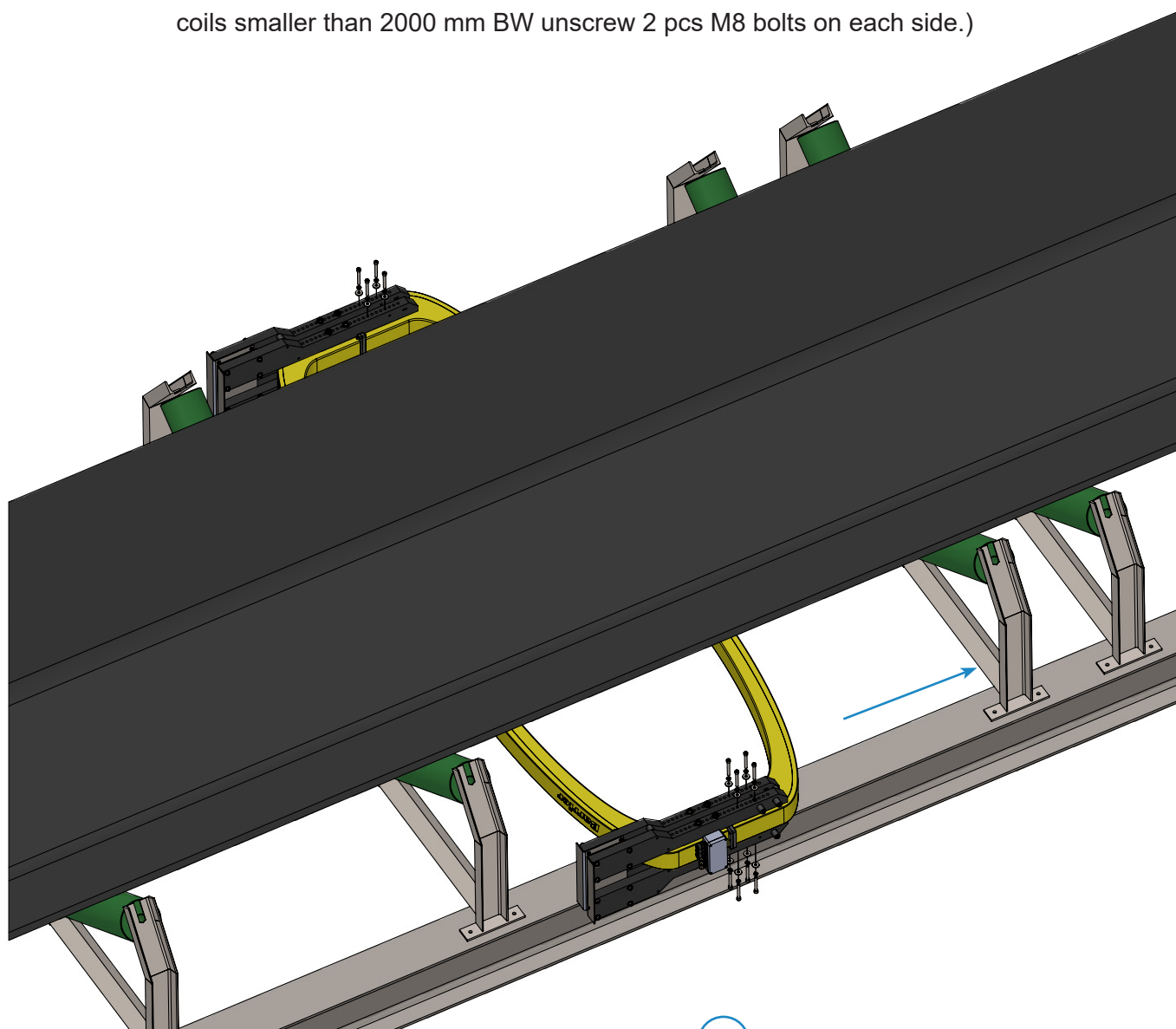

TECH

BAR

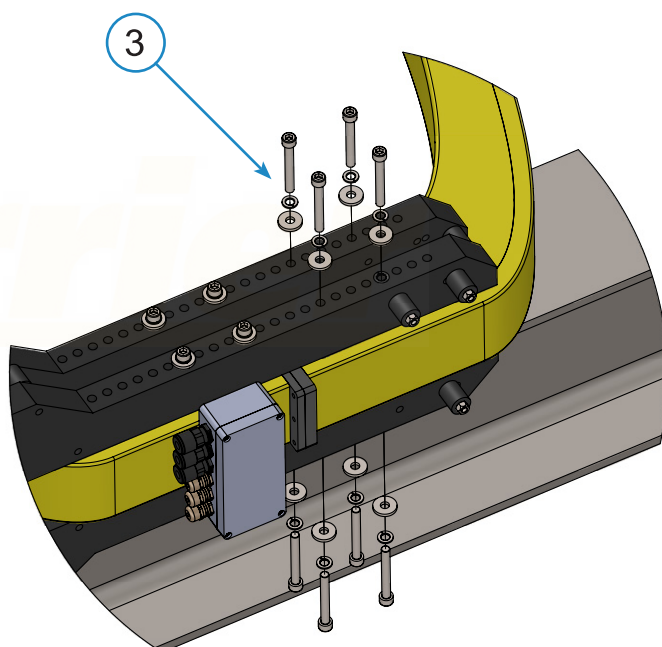

STEP 4 Carefully detach the upper frame evenly from each side of the coil.

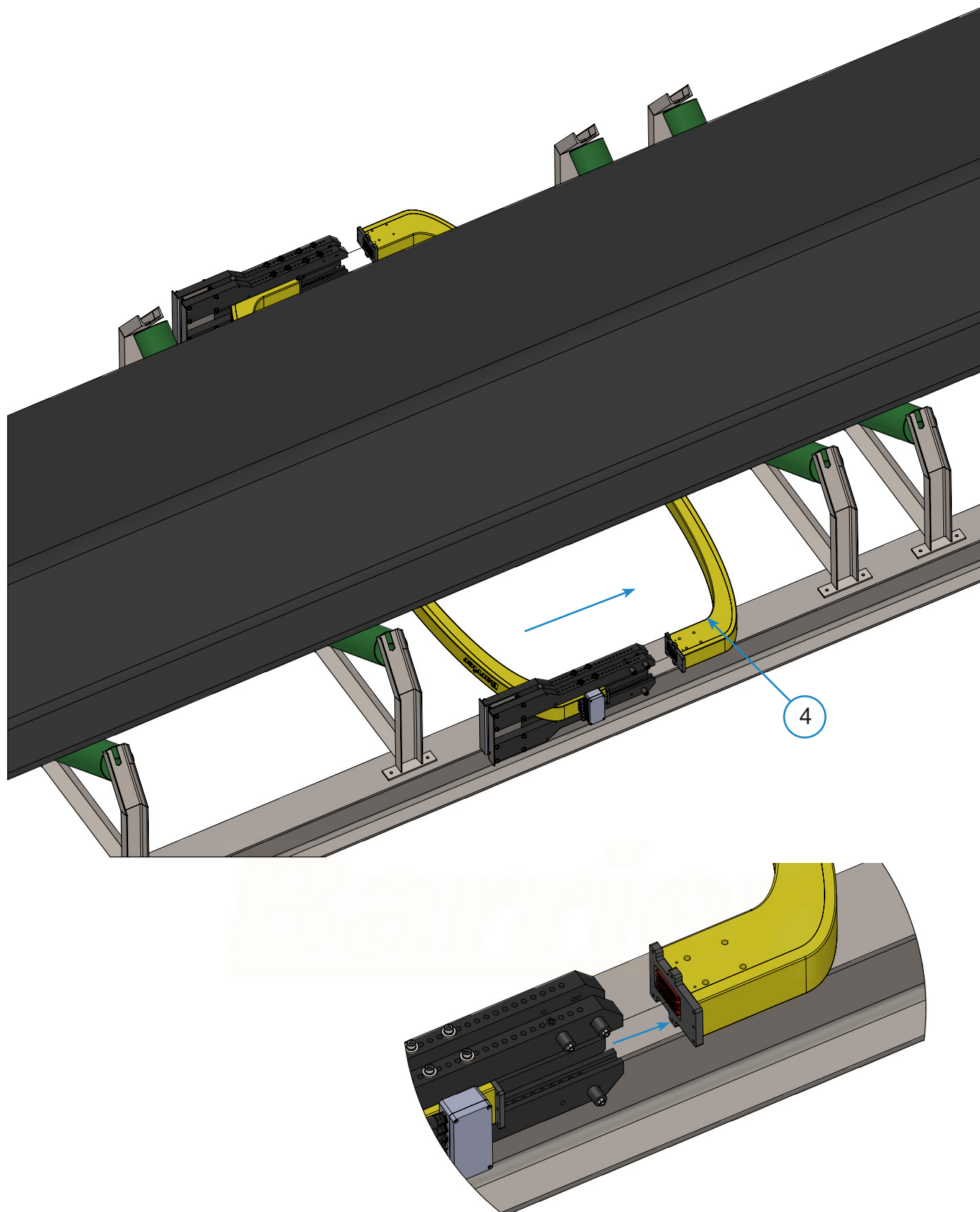

STEP 5 Carefully set the coil in the vertical position. Be aware that without the upper frame the structural rigidity is reduced.

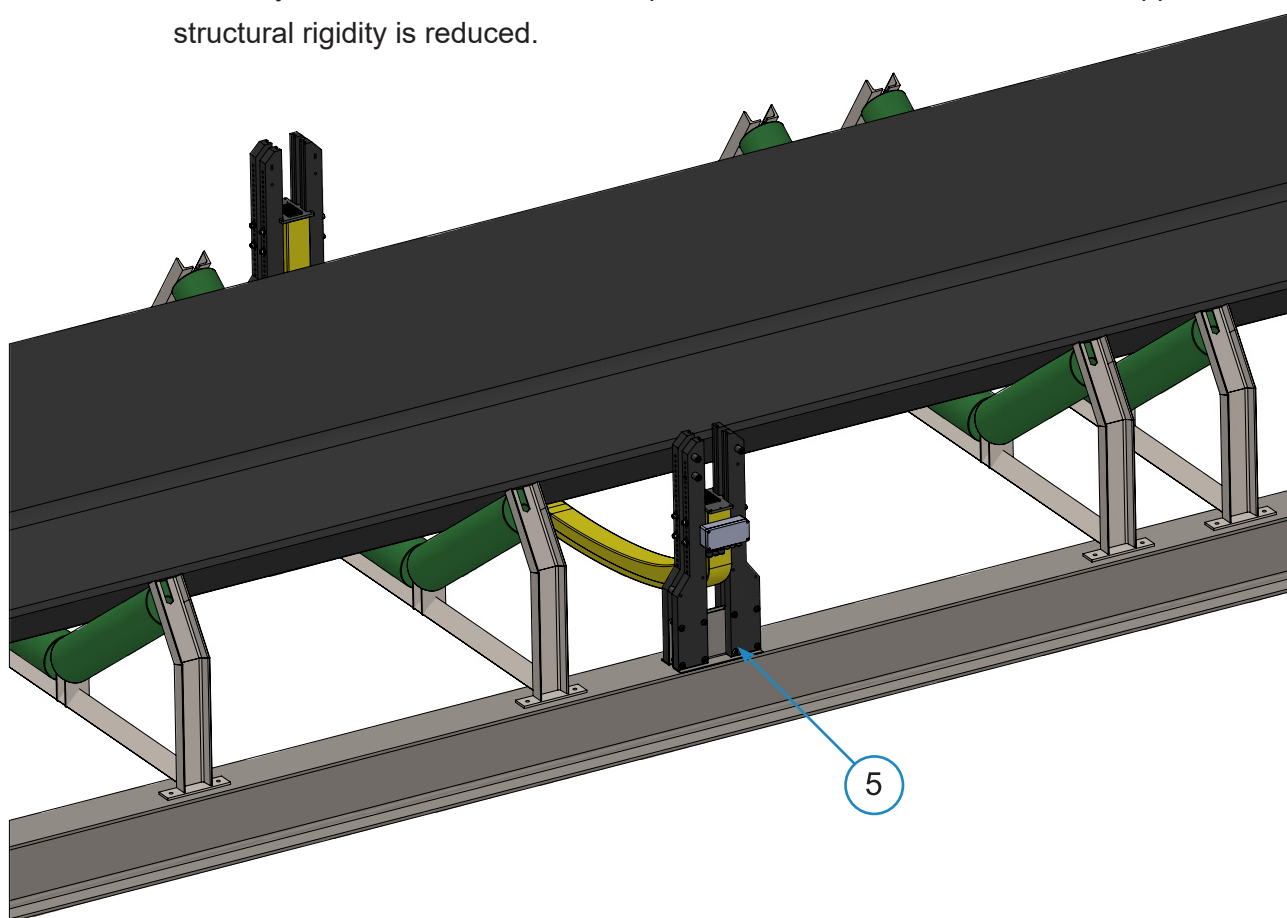

STEP 6 Install the upper frame evenly from both sides. Align the plug guiding keys with the receptacle keyways and insert the male pins straight into the female sockets until fully seated.

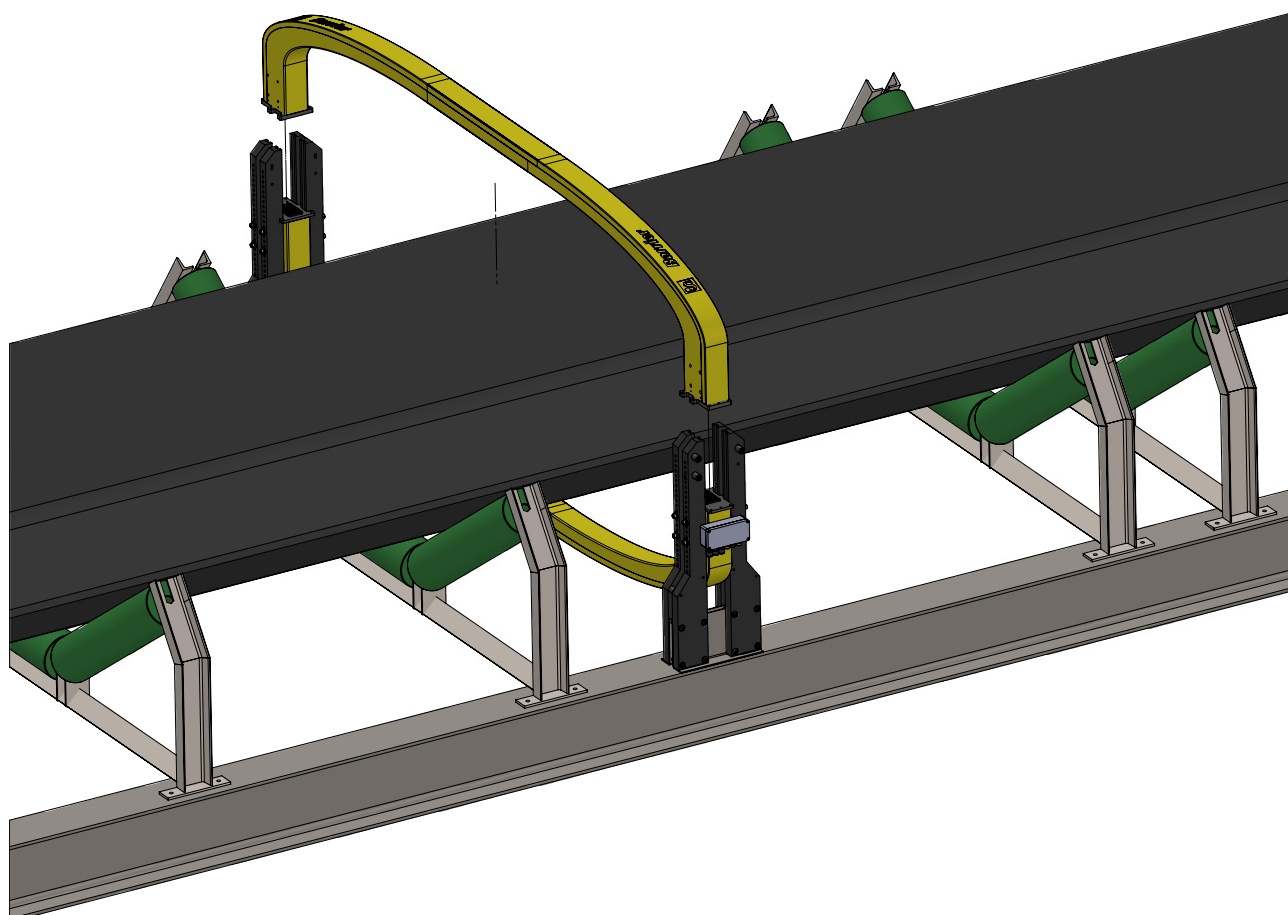

STEP 7 Reinstall 7 pcs M6 bolts on each side of the coil in the reverse order of Step 2. For coils with belt width less than 2000 mm reinstall 4 pcs M8 bolts on each side.

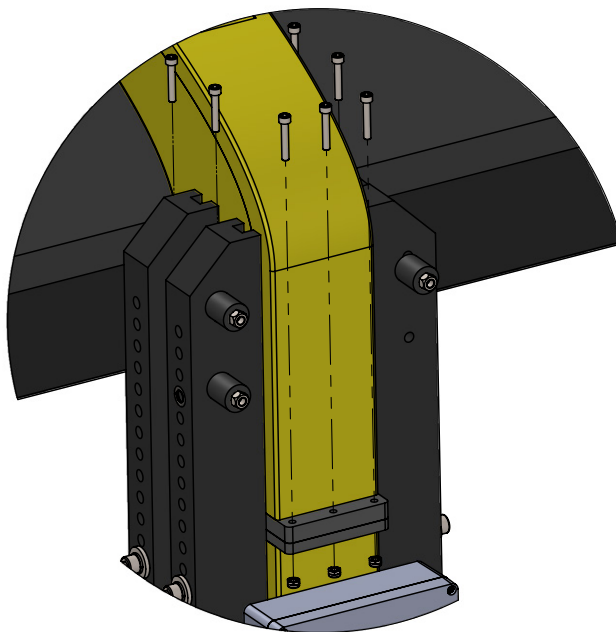

STEP 8 Reinstall 4 pcs M10 bolts on each side of the coil that secure the upper frame section in the reverse order of Step 3. For coils with belt width less than 2000 mm reinstall 2 pcs M8 bolts on each side.

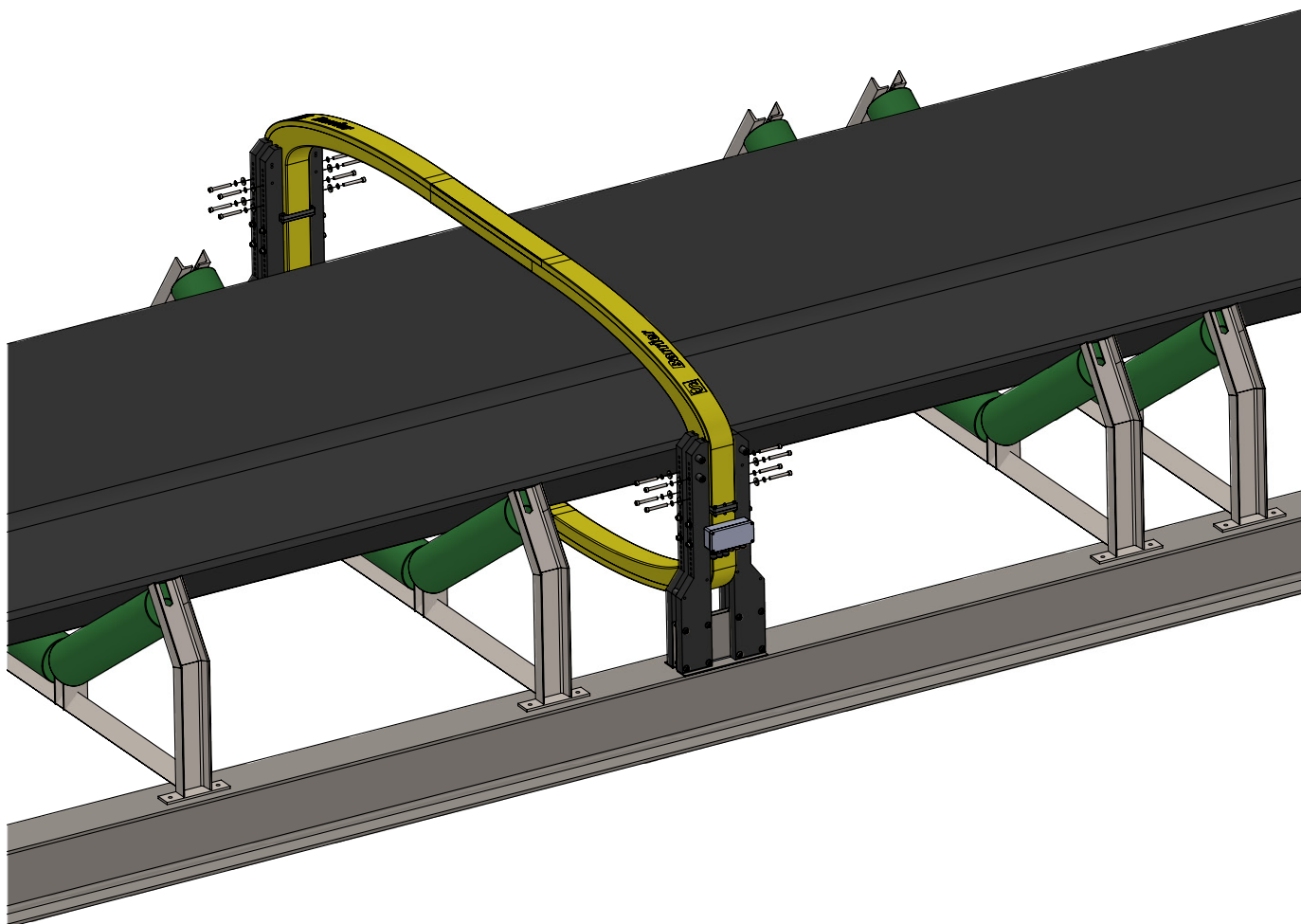

STEP 9 Reinstall 7 pcs M6 bolts on each side of the coil in the reverse order of Step 2. For coils with belt width less than 2000 mm reinstall 4 pcs M8 bolts on each side.

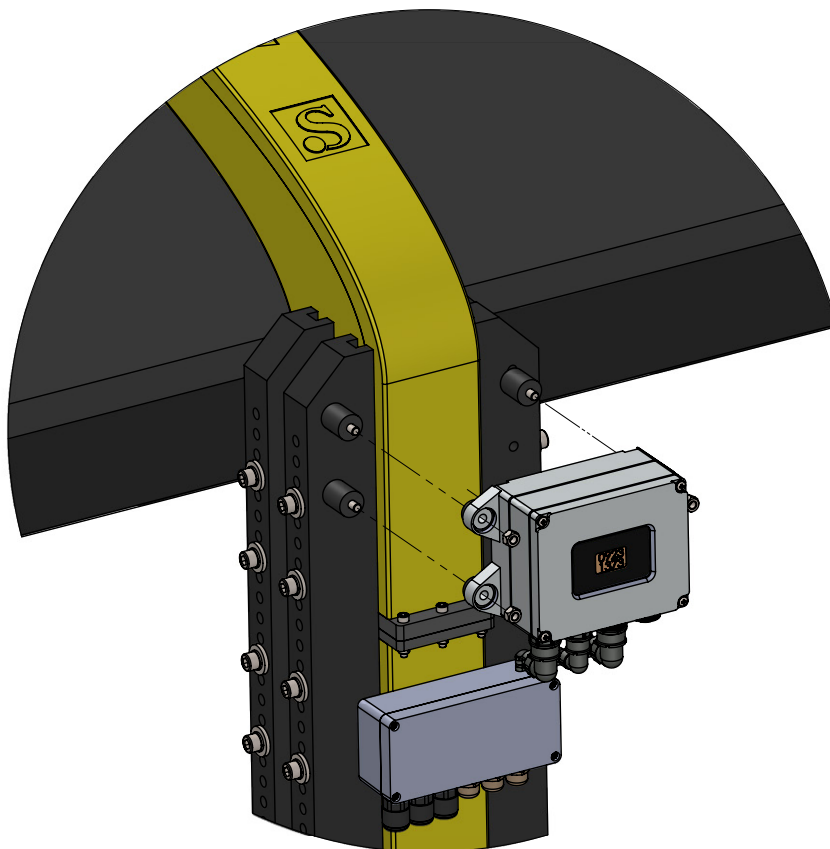

STEP 10 Install the 2M409F module in the prepared mounting locations on the coil and secure it with M8 nuts. Connect the corresponding connectors to the module according to “Annex 2. Connection and wiring schematics”.

